

DETAIL B  
SCALE 4 : 1

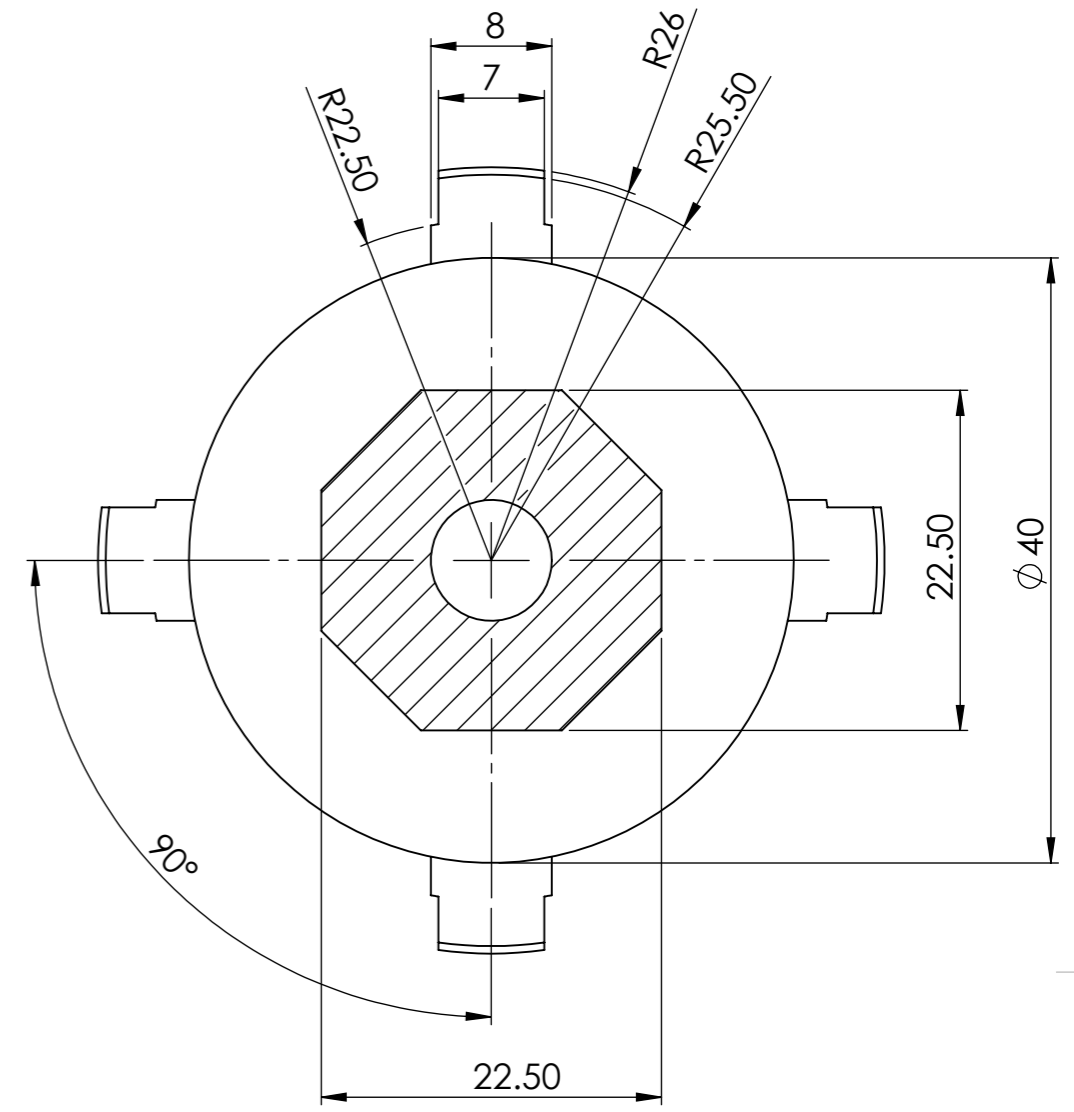

SECTION D-D  
SCALE 2 : 1

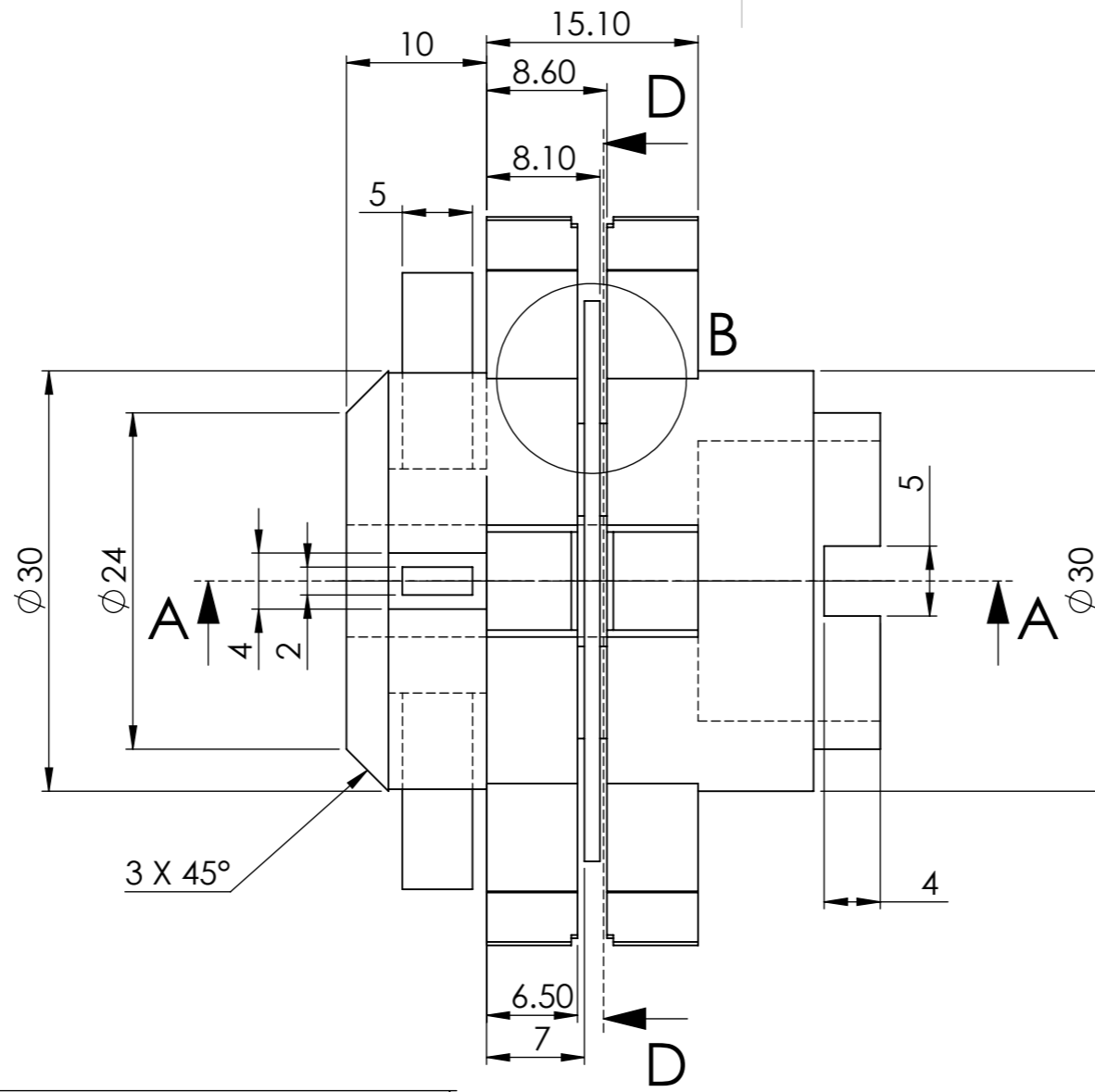
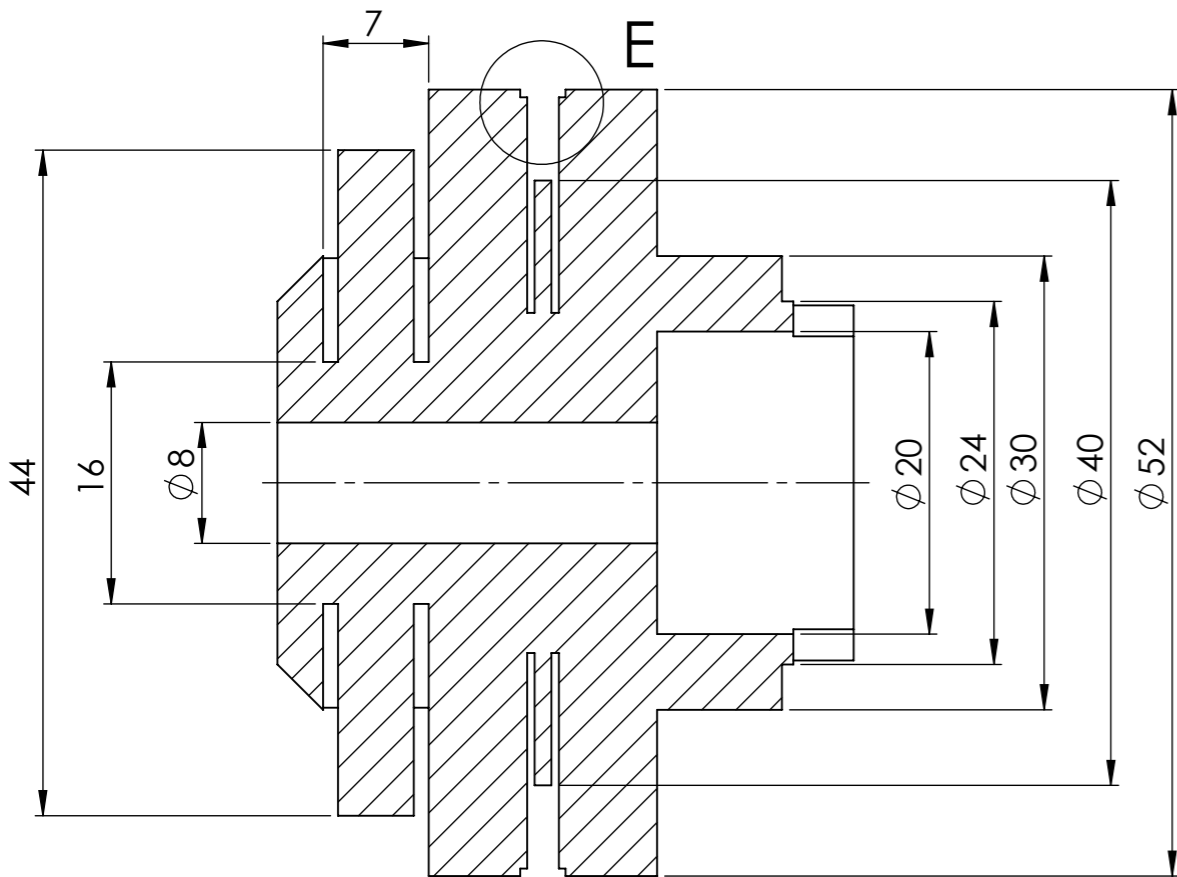

SECTION A-A  
SCALE 2 : 1

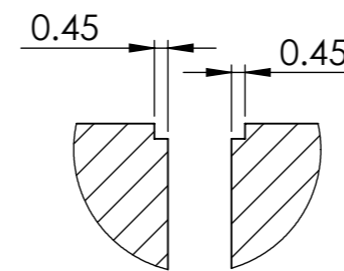

DETAIL E  
SCALE 4 : 1

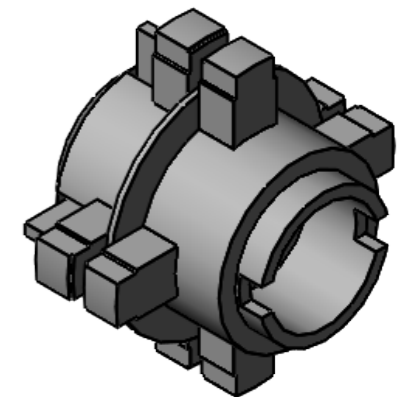

UNLESS OTHERWISE SPECIFIED:  
1. BREAK SHARP EDGES TO 0.2 x 45°  
2. UNSPECIFIED FILLET RADII TO R0.2  
3. ALL DIMENSIONS APPLY TO THE PART IN ITS FINISHED STATE AT 20°C  
4. DIMENSIONS IN [mm]

TOLERANCES (U.O.S.)  
XX.XX ±0.02  
XX.X ±0.05  
XX ±0.1  
ANGLES ±0.5°

DO NOT SCALE DRAWING

REVISION 2

| NAME            | SIGNATURE | DATE     |
|-----------------|-----------|----------|
| DRAWN A. Burger |           | 04/07/17 |
| CHK'D           |           |          |
| APPV'D          |           |          |
| MFG             |           |          |



TITLE:

DWG NO.

Diaphragm\_PM\_AB

| DRAWING PURPOSE | MATERIAL:      | WEIGHT: |
|-----------------|----------------|---------|
| Quotation       | Maraging Steel |         |
| Manufacturing   |                |         |
| Reference       |                |         |

SCALE:1:1

SHEET 1 OF 1