

ANNEXURE G: DRAWINGS

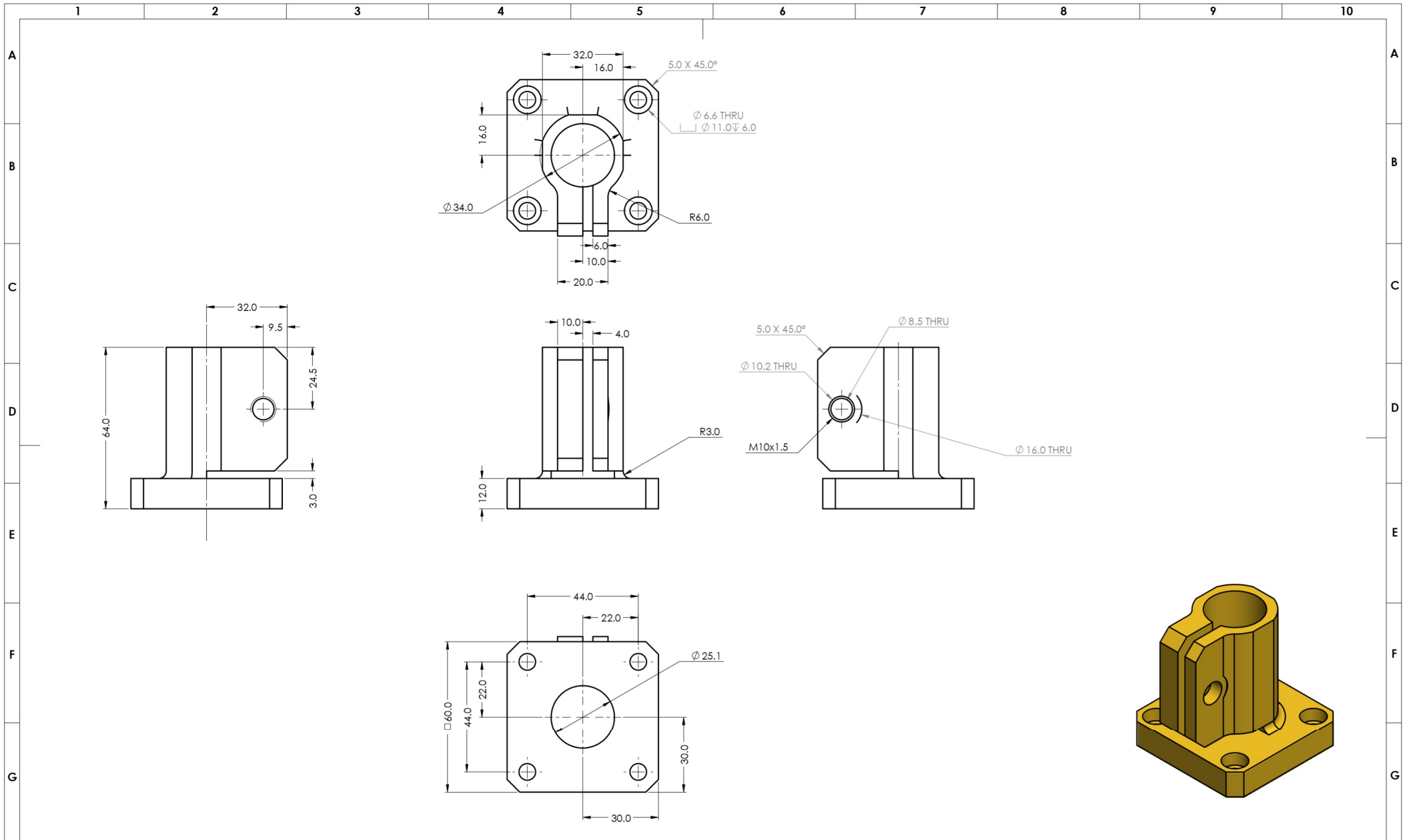

<p>TOLERANCES UNLESS OTHERWISE SPECIFIED</p> <p>LINEAR: TWO DECIMALS - ± 0.05 mm ONE DECIMAL - ± 0.1 mm NO DECIMAL - ± 0.5 mm</p> <p>ANGULAR: $\pm 0.5^\circ$</p>	DATE	DRAWN	CHECKED	APPROVED	DO NOT SCALE DRAWING	3 RD ANGLE PROJECTION	TITLE:	QUANTITY
	2023-07-01	C vd Westhuizen			DEBUR AND REMOVE SHARP EDGES	MATERIAL:	Castor rod clamp	4
					SURFACE FINISH 1.4 μ m	Brass	PART NO:	
					SHEET 1 OF 1	TREATMENT:		
A2	ASK WHEN IN DOUBT	DRAWING STANDARD: BS 8888: 2002		DIMENSIONS IN MILLIMETRES	COPYRIGHT RESERVED	SCALE: 1:1	REVISION: 01	TEL:(012) 841 3067

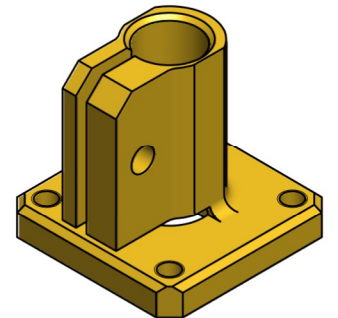

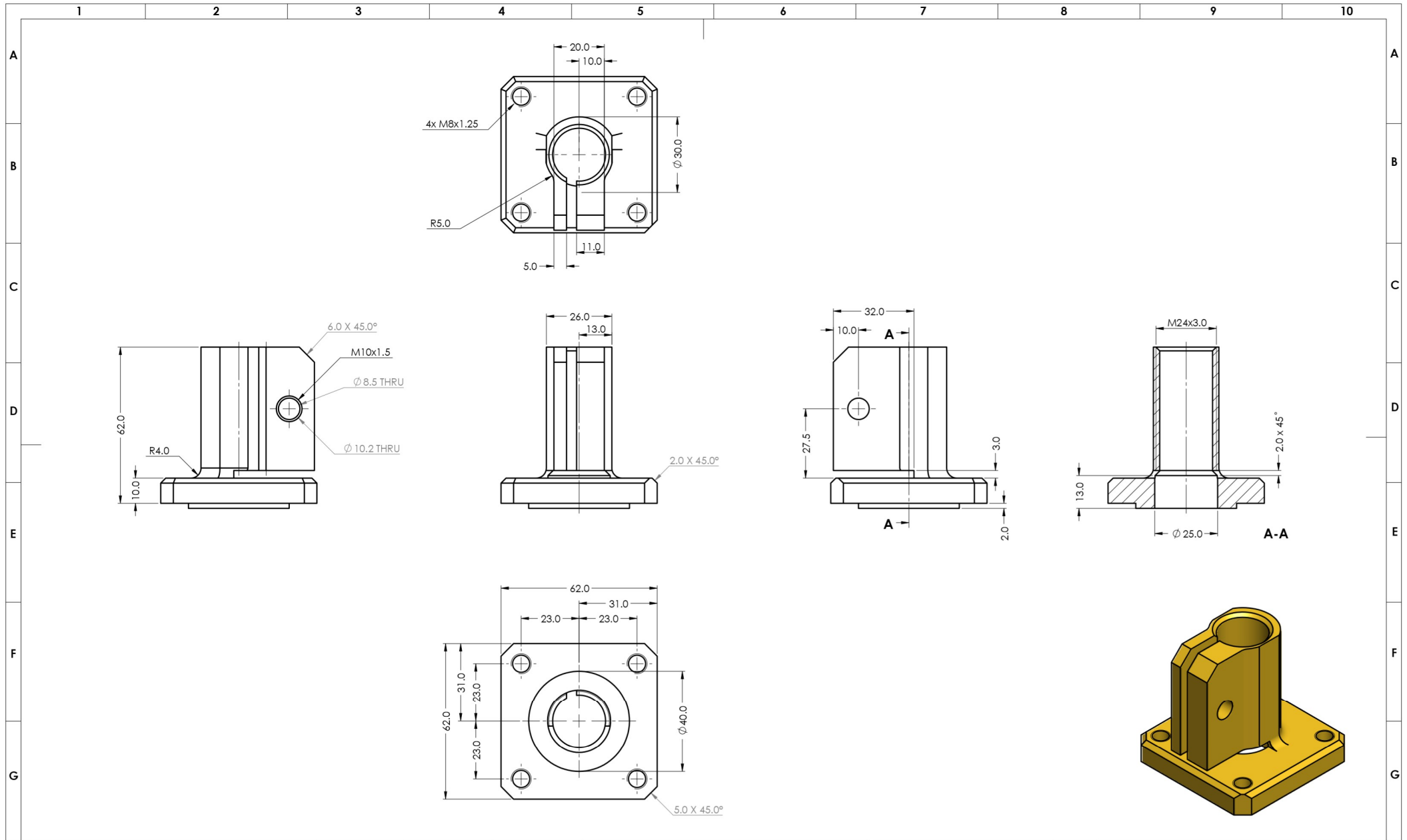

TOLERANCES UNLESS OTHERWISE SPECIFIED LINEAR: TWO DECIMALS - ± 0.05 mm ONE DECIMAL - ± 0.1 mm NO DECIMAL - ± 0.5 mm ANGULAR: ± 0.5°	DATE	DRAWN	CHECKED	APPROVED	DO NOT SCALE DRAWING	3 RD ANGLE PROJECTION	TITLE:	QUANTITY		
	2023-07-03	C vd Westhuizen			DEBUR AND REMOVE SHARP EDGES	MATERIAL:	Castor stud clamp	4		
					SURFACE FINISH 1.4 µm SHEET 1 OF 1	Brass	PART NO:			
						TREATMENT:				
A2	ASK WHEN IN DOUBT				DRAWING STANDARD: BS 8888: 2002	DIMENSIONS IN MILLIMETRES	COPYRIGHT RESERVED	SCALE: 1:1	REVISION: 01	TEL:(012) 841 3067



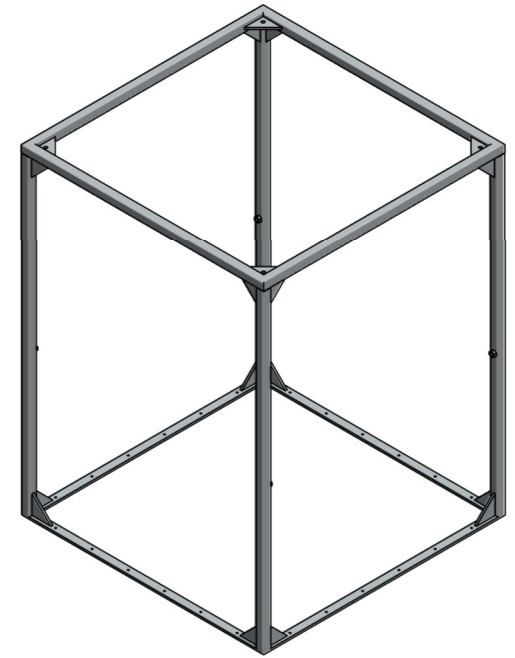
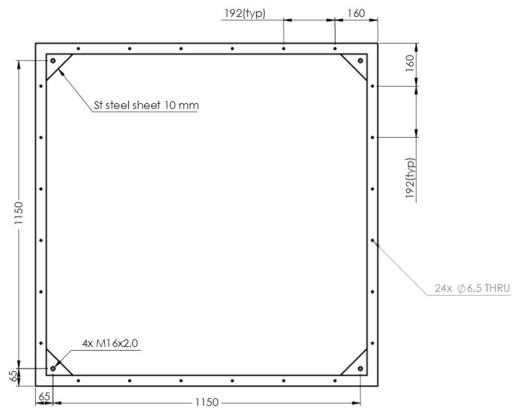
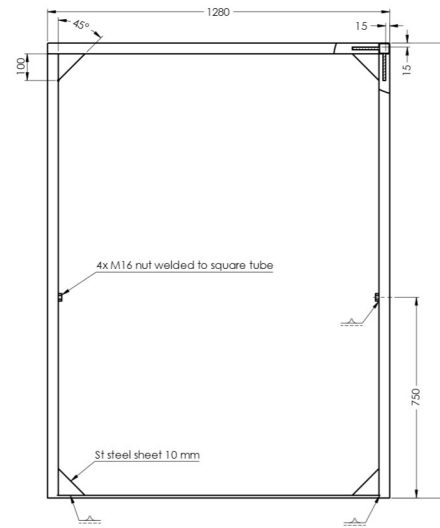
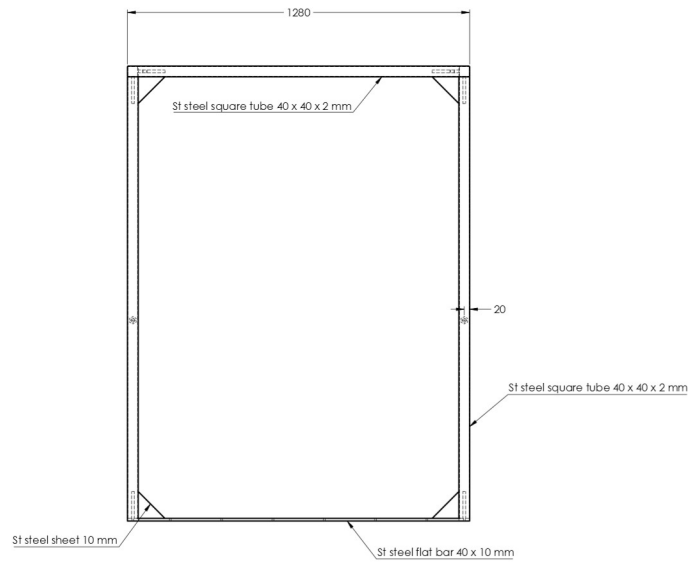

TOLERANCES UNLESS OTHERWISE SPECIFIED
 LINEAR: TWO DECIMALS - ± 0.05 mm
 ONE DECIMAL - ± 0.1 mm
 NO DECIMAL - ± 0.5 mm
 ANGULAR: ± 0.5°

DATE	DRAWN	CHECKED	APPROVED
2023-07-20	C vd Westhuizen		

DO NOT SCALE DRAWING

3 RD ANGLE PROJECTION

DEBUR AND BREAK SHARP EDGES

MATERIAL: St steel

SURFACE FINISH: 1.4 µm

SHEET 1 OF 1

TREATMENT:

TITLE:	QUANTITY
Chiller st steel frame	1
PART NO:	



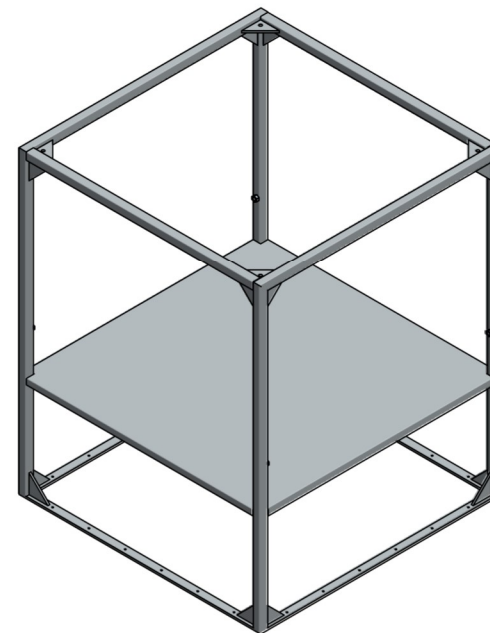
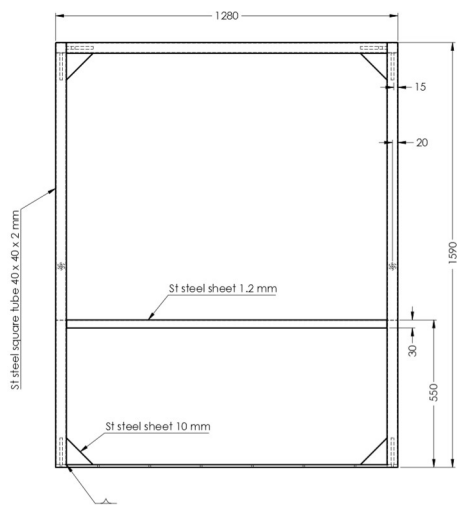
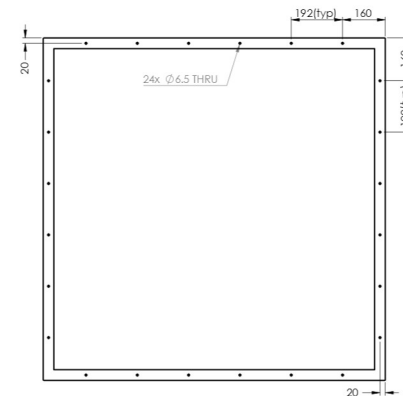
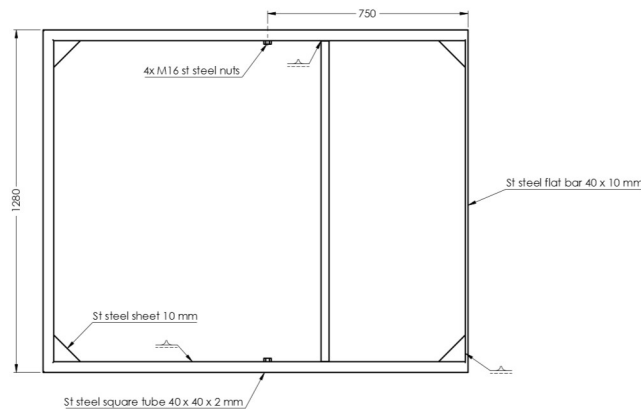
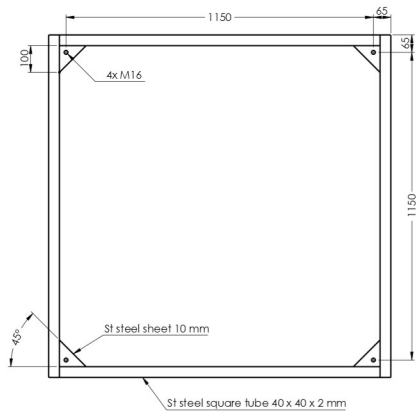

TOLERANCES UNLESS OTHERWISE SPECIFIED
 LINEAR: TWO DECIMALS - ± 0.05 mm
 ONE DECIMAL - ± 0.1 mm
 NO DECIMAL - ± 0.5 mm
 ANGULAR: $\pm 0.5^\circ$

DATE	DRAWN	CHECKED	APPROVED
2023-09-01	C vd Westhuizen		

DO NOT SCALE DRAWING

3 RD ANGLE PROJECTION

TITLE:
Electronics rack + frame assembly

QUANTITY
1

DEBUR AND BREAK SHARP EDGES

MATERIAL:
See bill of material

PART NO:

SURFACE FINISH: 1.4 μ m

SHEET 1 OF 1

TREATMENT:



A1

ASK WHEN IN DOUBT

DRAWING STANDARD: 8888 2002

DIMENSIONS IN MILLIMETRES

COPYRIGHT RESERVED

SCALE: 1:10 REVISION: 01

TEL: 012 841 3067

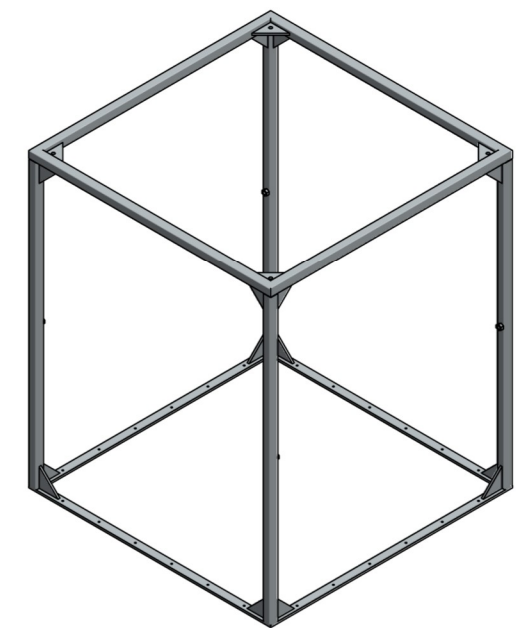
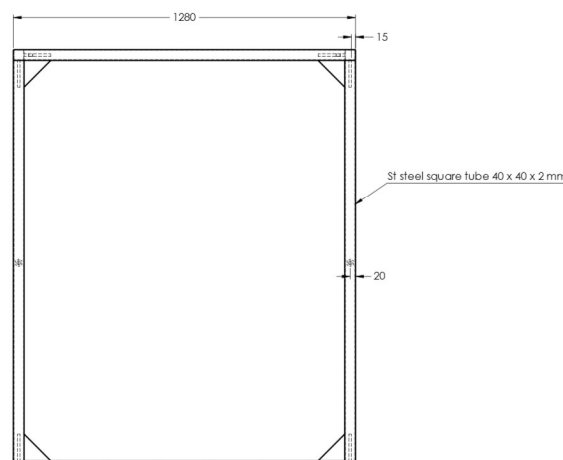
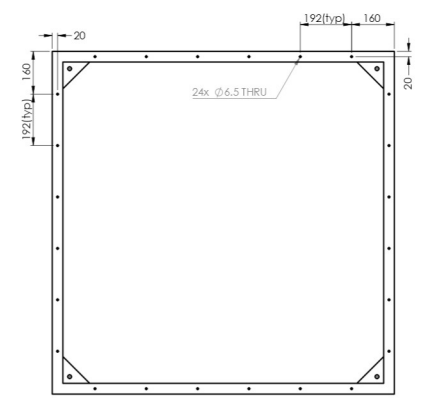
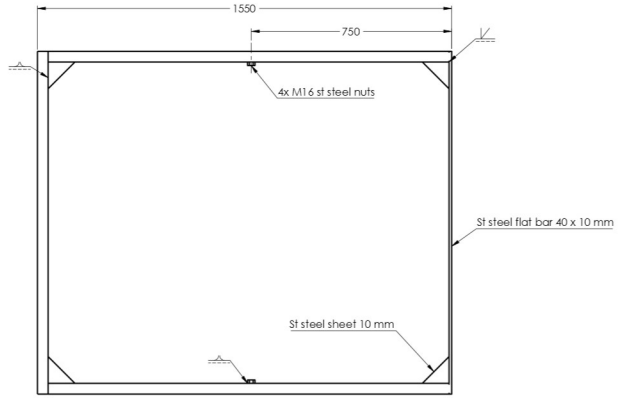
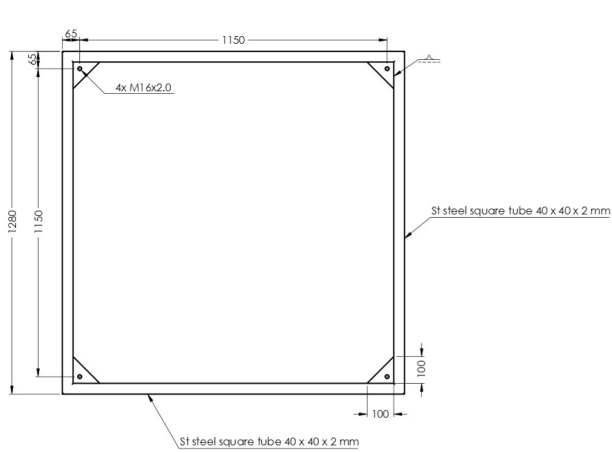

TOLERANCES UNLESS OTHERWISE SPECIFIED
 LINEAR: TWO DECIMALS - ± 0.05 mm
 ONE DECIMAL - ± 0.1 mm
 NO DECIMAL - ± 0.5 mm
 ANGULAR: ± 0.5°

DATE	DRAWN	CHECKED	APPROVED
2023-07-19	C vd Westhuizen		

DO NOT SCALE DRAWING
 DEBUR AND BREAK SHARP EDGES
 SURFACE FINISH: 1.4 µm
 SHEET 1 OF 1

3 RD ANGLE PROJECTION
 MATERIAL: St steel
 TREATMENT:

TITLE: Laser st steel frame
 PART NO:

QUANTITY: 1



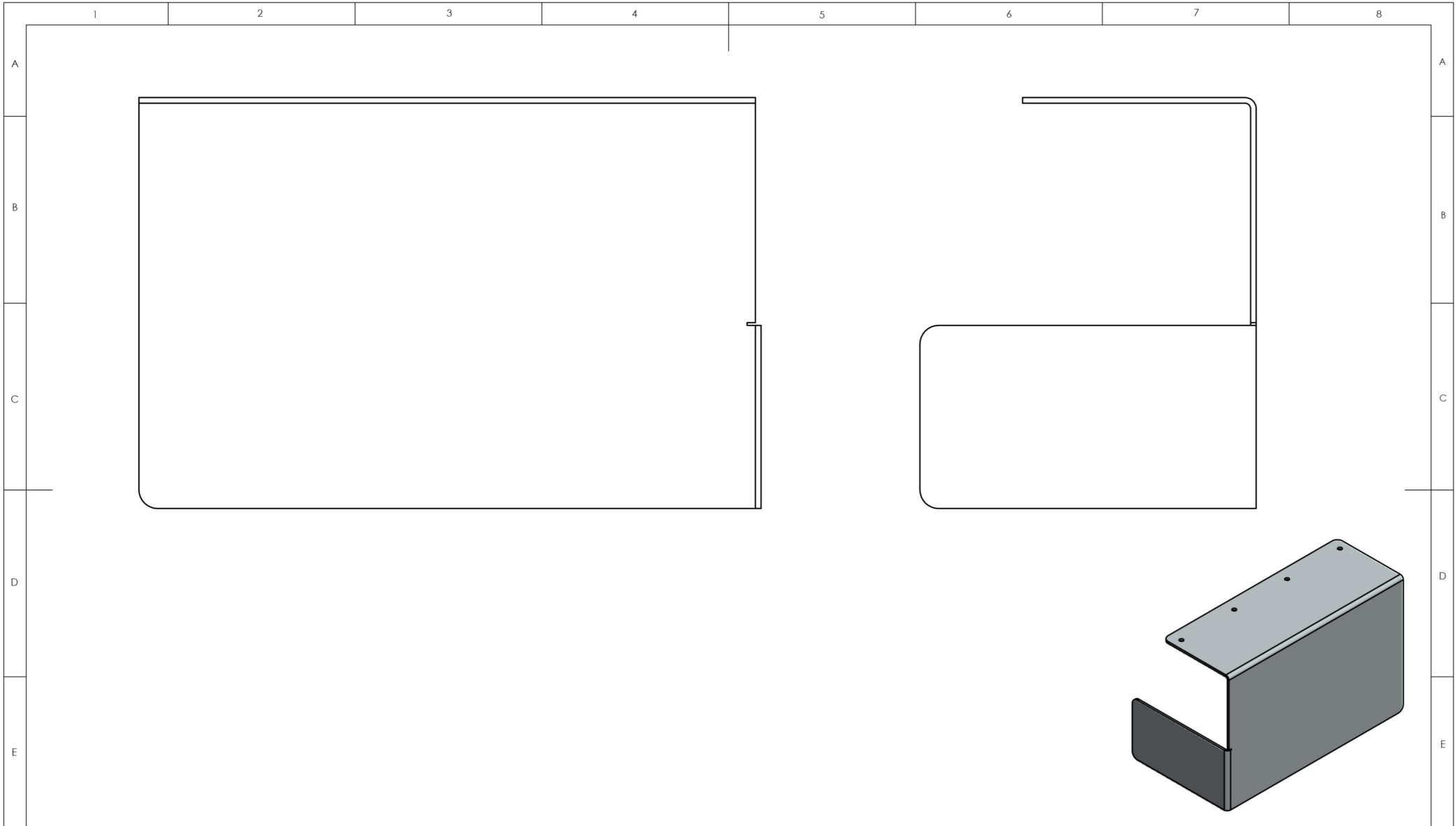

UNLESS OTHERWISE SPECIFIED TOLERANCES: LINEAR: TWO DECIMALS - 0.05 mm ONE DECIMAL - ± 0.1 mm NO DECIMAL - ± 0.5 mm ANGULAR: ± 0.5° SURFACE FINISH: μ 1.4 DEBUR AND BREAK SHARP EDGES	DO NOT SCALE DRAWING		SHEET 1 OF 1		3 RD ANGLE PROJECTION 		TITLE:	QUANTITY	
	DATE:	DRAWN BY:	CHECKED	APPROVED	MATERIAL:	Mild steel sheet 3 mm	Pallet protection cover	4	
	202-06-09	C vd Westhuizen			TREATMENT:		DWG NO.		
A3	DRAWING STANDARD: BS 8888: 2002		DIMENSIONS ARE IN MILLIMETERS		COPYRIGHT RESERVED		SCALE: 1:2	REVISION 01	TEL:(012) 841 3067



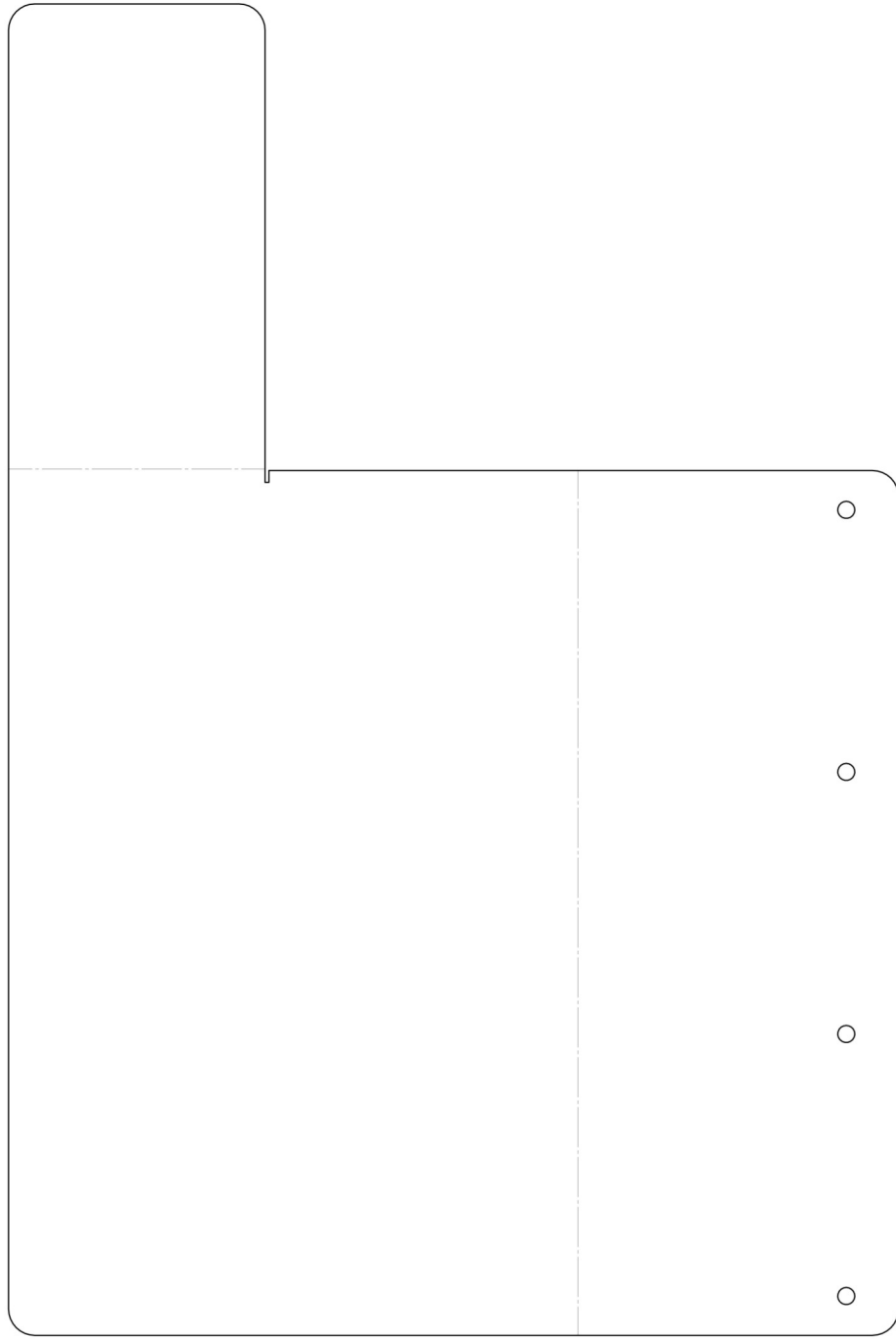

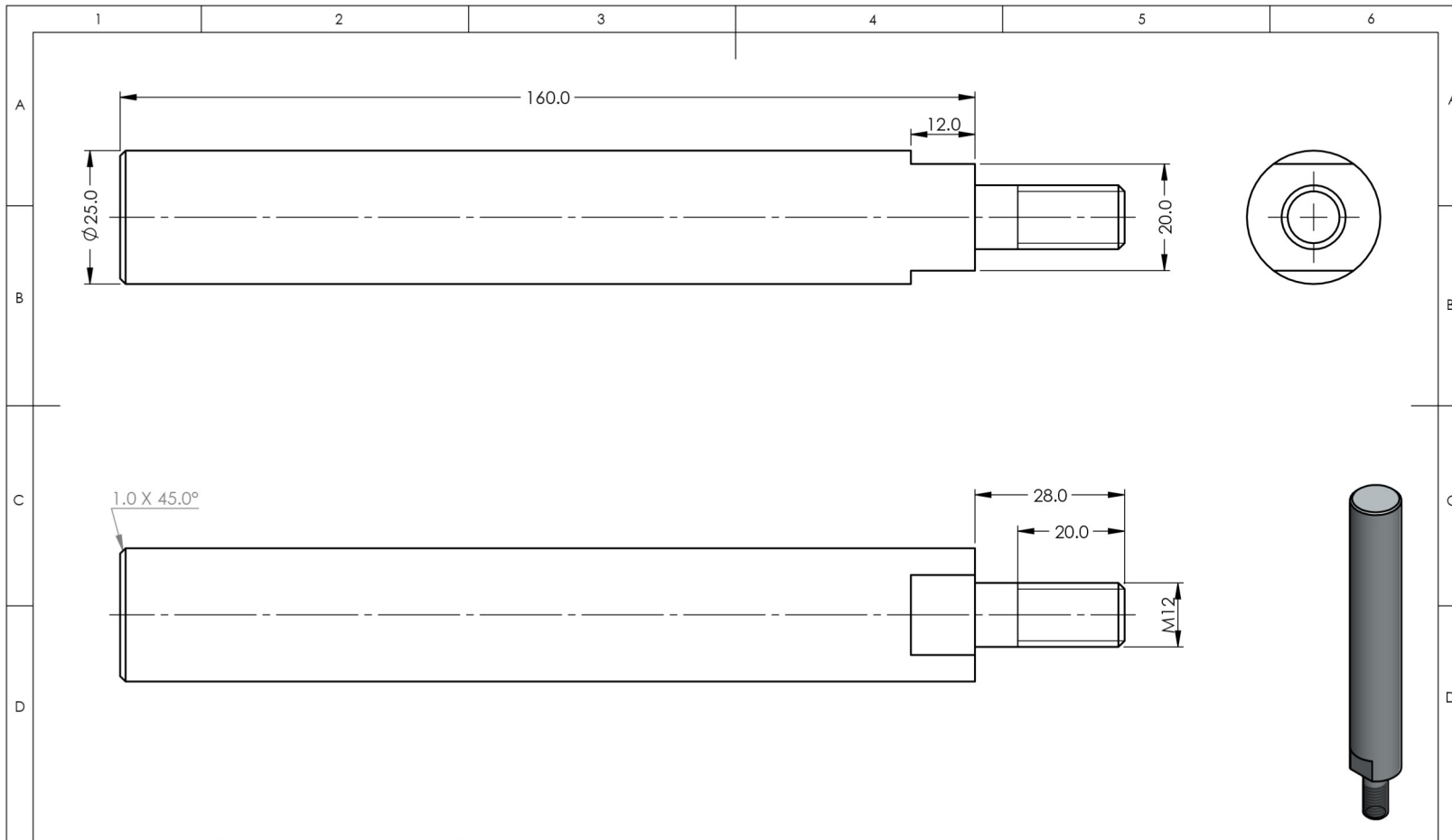

TOLERANCES UNLESS OTHERWISE SPECIFIED LINEAR: TWO DECIMALS - $\pm 0.05\text{mm}$ ONE DECIMAL - $\pm 0.1\text{mm}$ NO DECIMAL - $\pm 0.5\text{mm}$ ANGULAR: $\pm 0.5^\circ$	DATE:	DRAWN BY:	CHECKED:	APPROVED:	DO NOT SCALE DRAWING	3 RD ANGLE PROJECTION	TITLE:	QUANTITY
	2023-06-29	C. vd Westhuizen			SURFACE FINISH $1.4\ \mu\text{m}$		MATERIAL:	Positioner castor rod
					DEBUR SHARP EDGES	St steel	PART NO.	
					SHEET 1 OF 1	TREATMENT:		

A4



DRAWING STANDARD: BS 8888: 2002 | DIMENSIONS ARE IN MILLIMETERS

COPYRIGHT RESERVED

SCALE: 1:1

REVISION: 01

TEL: 012 841 3067

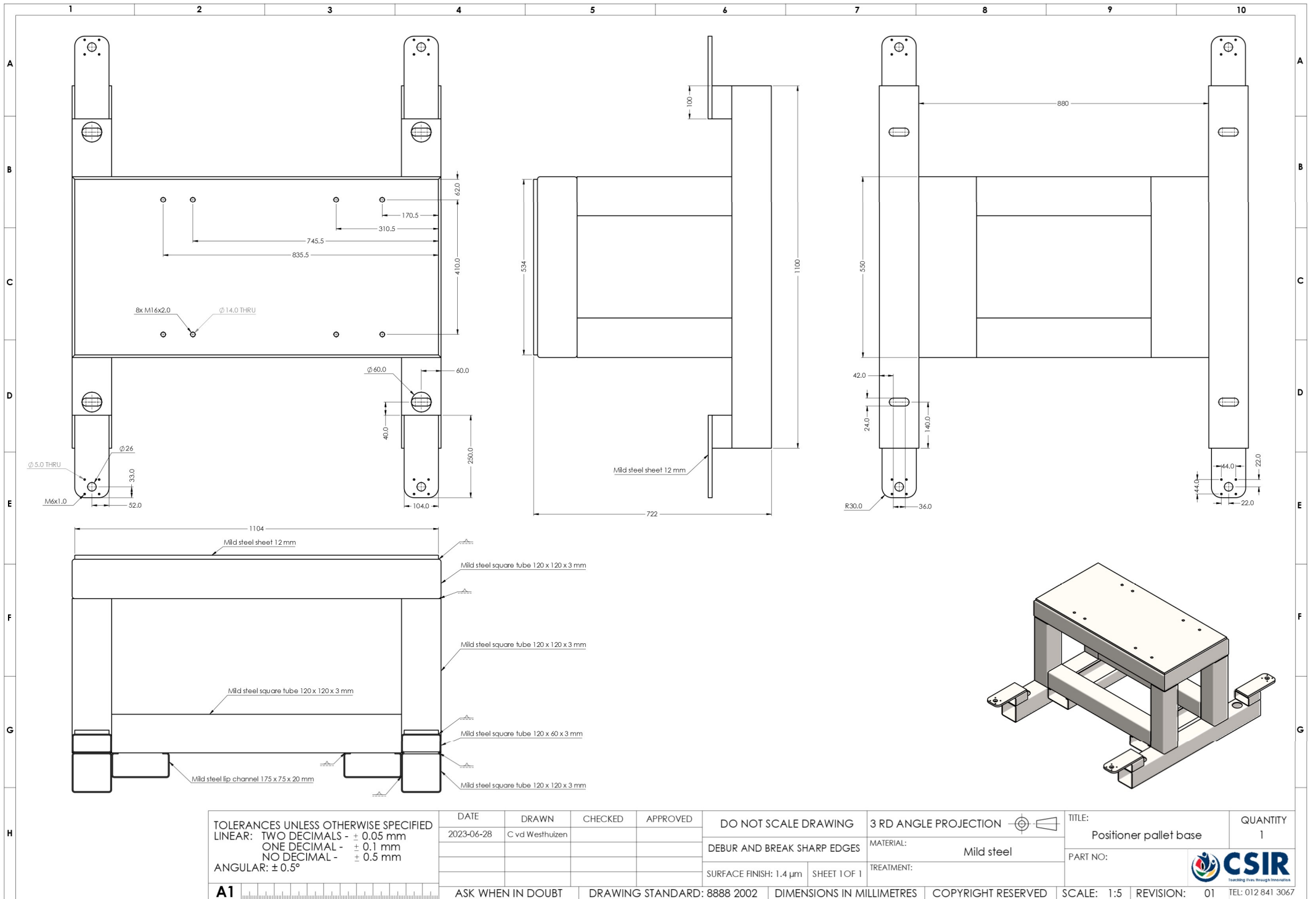

TOLERANCES UNLESS OTHERWISE SPECIFIED
 LINEAR: TWO DECIMALS - ± 0.05 mm
 ONE DECIMAL - ± 0.1 mm
 NO DECIMAL - ± 0.5 mm
 ANGULAR: ± 0.5°

DATE	DRAWN	CHECKED	APPROVED
2023-06-28	C vd Westhuizen		

DO NOT SCALE DRAWING	3 RD ANGLE PROJECTION
DEBUR AND BREAK SHARP EDGES	MATERIAL: Mild steel
SURFACE FINISH: 1.4 µm	TREATMENT:
SHEET 1 OF 1	

TITLE: Positioner pallet base	QUANTITY: 1
PART NO:	
 <small>Leading the way through innovation</small>	

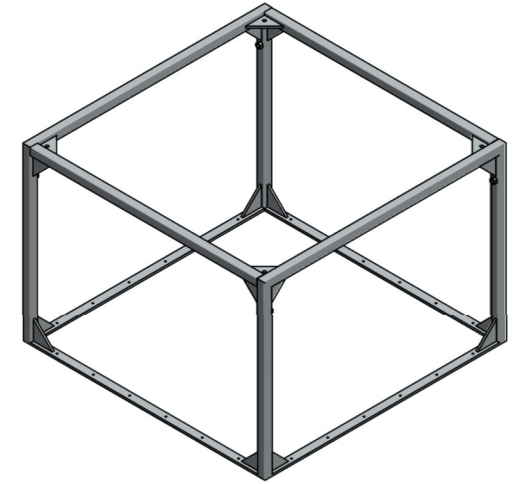
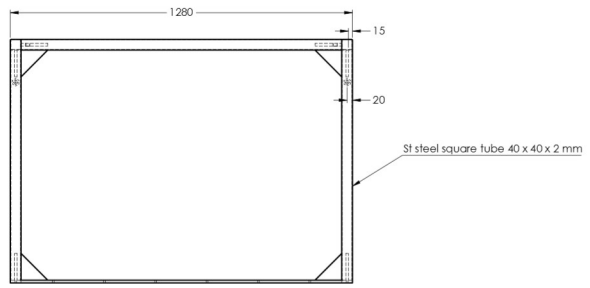
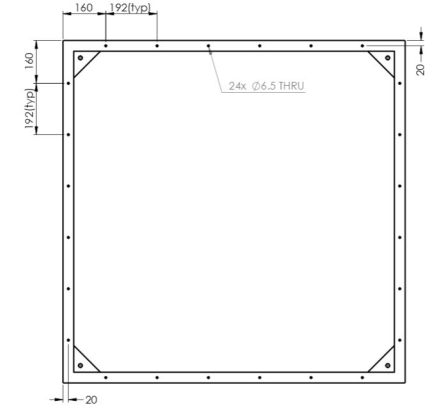
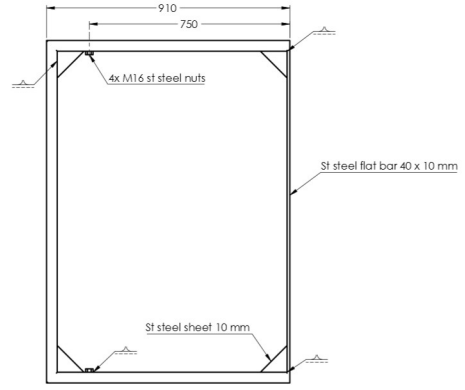
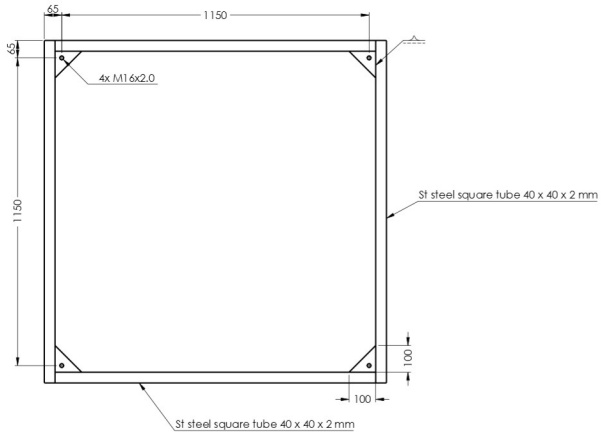

TOLERANCES UNLESS OTHERWISE SPECIFIED
 LINEAR: TWO DECIMALS - ± 0.05 mm
 ONE DECIMAL - ± 0.1 mm
 NO DECIMAL - ± 0.5 mm
 ANGULAR: $\pm 0.5^\circ$

DATE	DRAWN	CHECKED	APPROVED
2023-08-22	C vd Westhuizen		

DO NOT SCALE DRAWING
 DEBUR AND BREAK SHARP EDGES
 SURFACE FINISH: 1.4 μ m

3 RD ANGLE PROJECTION 
 MATERIAL: St steel
 TREATMENT:
 SHEET 1 OF 1

TITLE: Powder feeder st steel frame
 QUANTITY: 1
 PART NO:

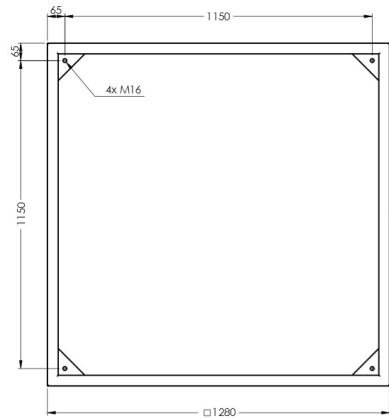

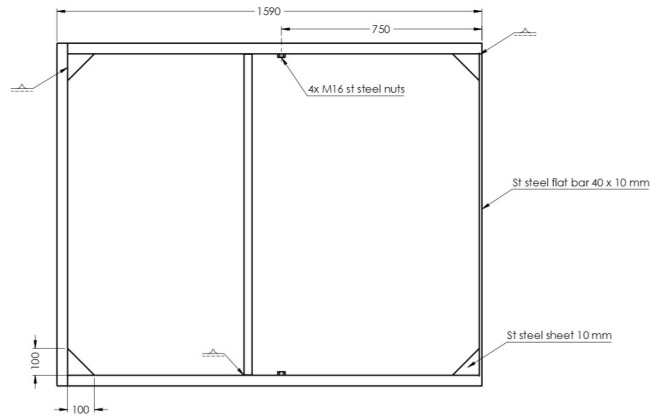

St steel square tube 40 x 40 x 2 mm

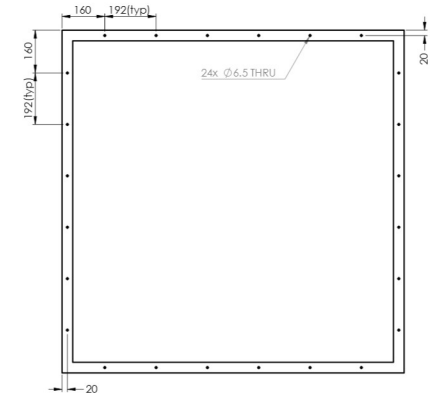

St steel flat bar 40 x 10 mm

St steel sheet 1.0 mm



24x Ø6.5 THRU

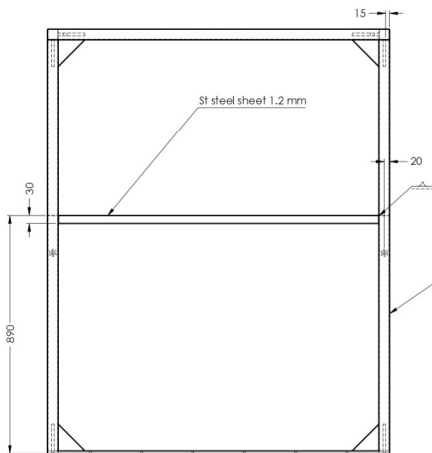

St steel sheet 1.2 mm

St steel square tube 40 x 40 x 2 mm

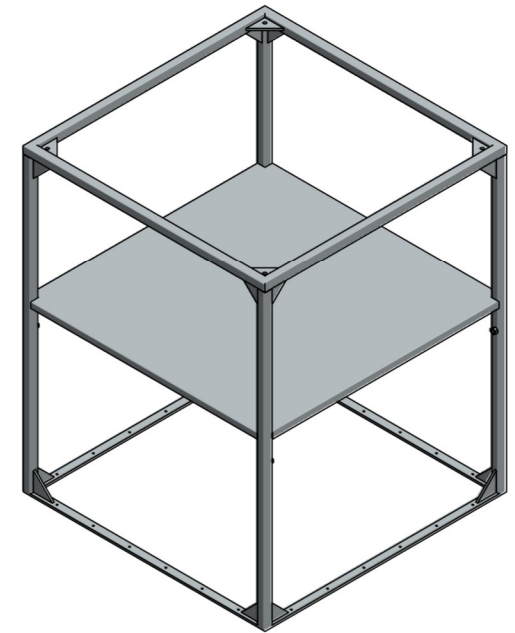

TOLERANCES UNLESS OTHERWISE SPECIFIED
 LINEAR: TWO DECIMALS - ± 0.05 mm
 ONE DECIMAL - ± 0.1 mm
 NO DECIMAL - ± 0.5 mm
 ANGULAR: ± 0.5°

DATE	DRAWN	CHECKED	APPROVED
2023-09-02	C vd Westhuizen		

DO NOT SCALE DRAWING

3 RD ANGLE PROJECTION

DEBUR AND BREAK SHARP EDGES

MATERIAL: See bill of material

SURFACE FINISH: 1.4 µm

SHEET 1 OF 1

TITLE: Robot controller rack + frame assembly

QUANTITY 1

PART NO:



A1

ASK WHEN IN DOUBT DRAWING STANDARD: 8888 2002 DIMENSIONS IN MILLIMETRES COPYRIGHT RESERVED SCALE: 1:10 REVISION: 01 TEL: 012 841 3067

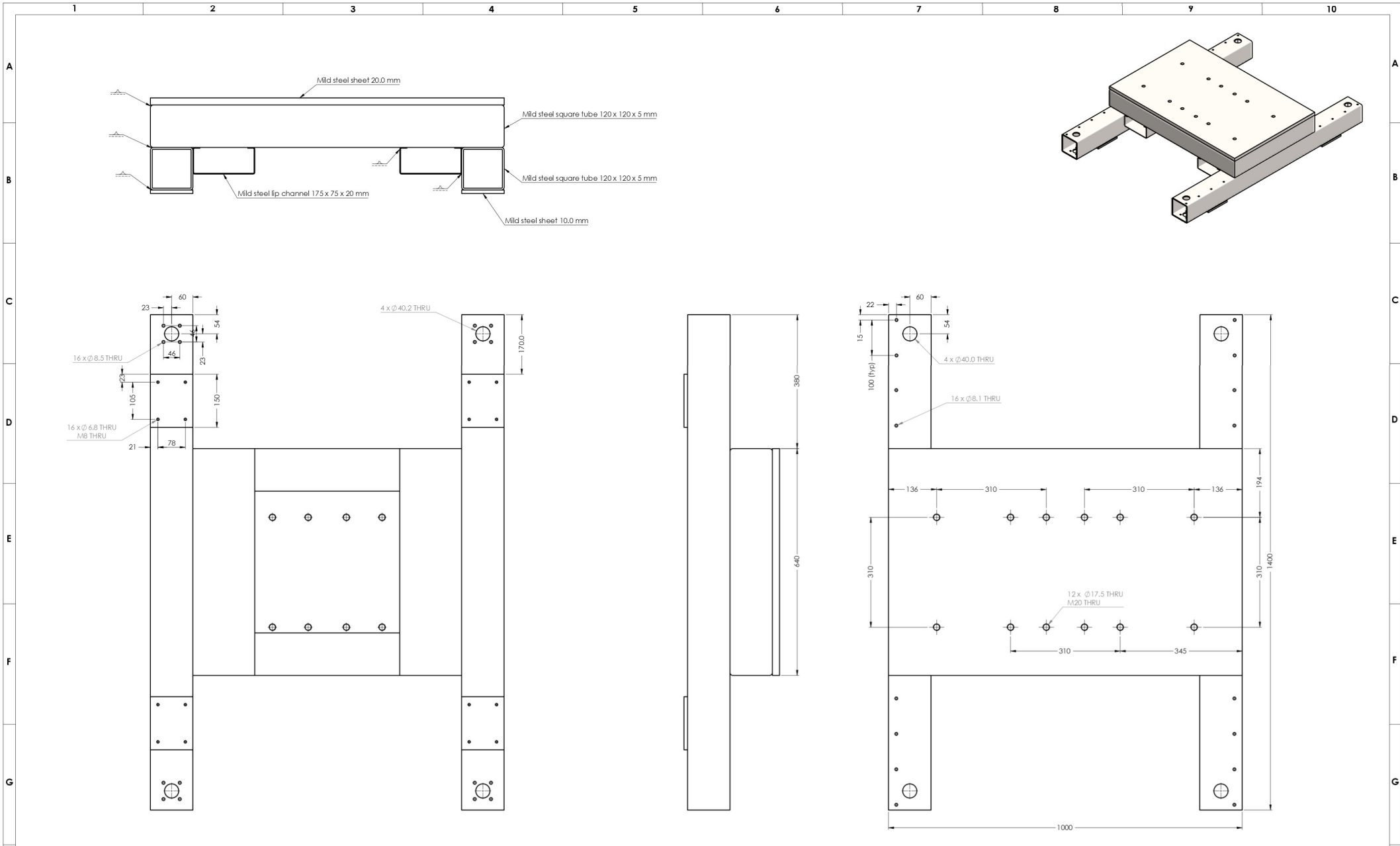

TOLERANCES UNLESS OTHERWISE SPECIFIED
 LINEAR: TWO DECIMALS - ± 0.05 mm
 ONE DECIMAL - ± 0.1 mm
 NO DECIMAL - ± 0.5 mm
 ANGULAR: ± 0.5°

DATE	DRAWN	CHECKED	APPROVED
2023-06-07	C vd Westhuizen		

DO NOT SCALE DRAWING
 DEBUR AND BREAK SHARP EDGES
 SURFACE FINISH:

3 RD ANGLE PROJECTION 
 MATERIAL: Mild steel
 TREATMENT:
 SHEET 1 OF 1

TITLE: Robot pallet base
 PART NO:

QUANTITY: 1

 CSIR
 Leading the way through innovation

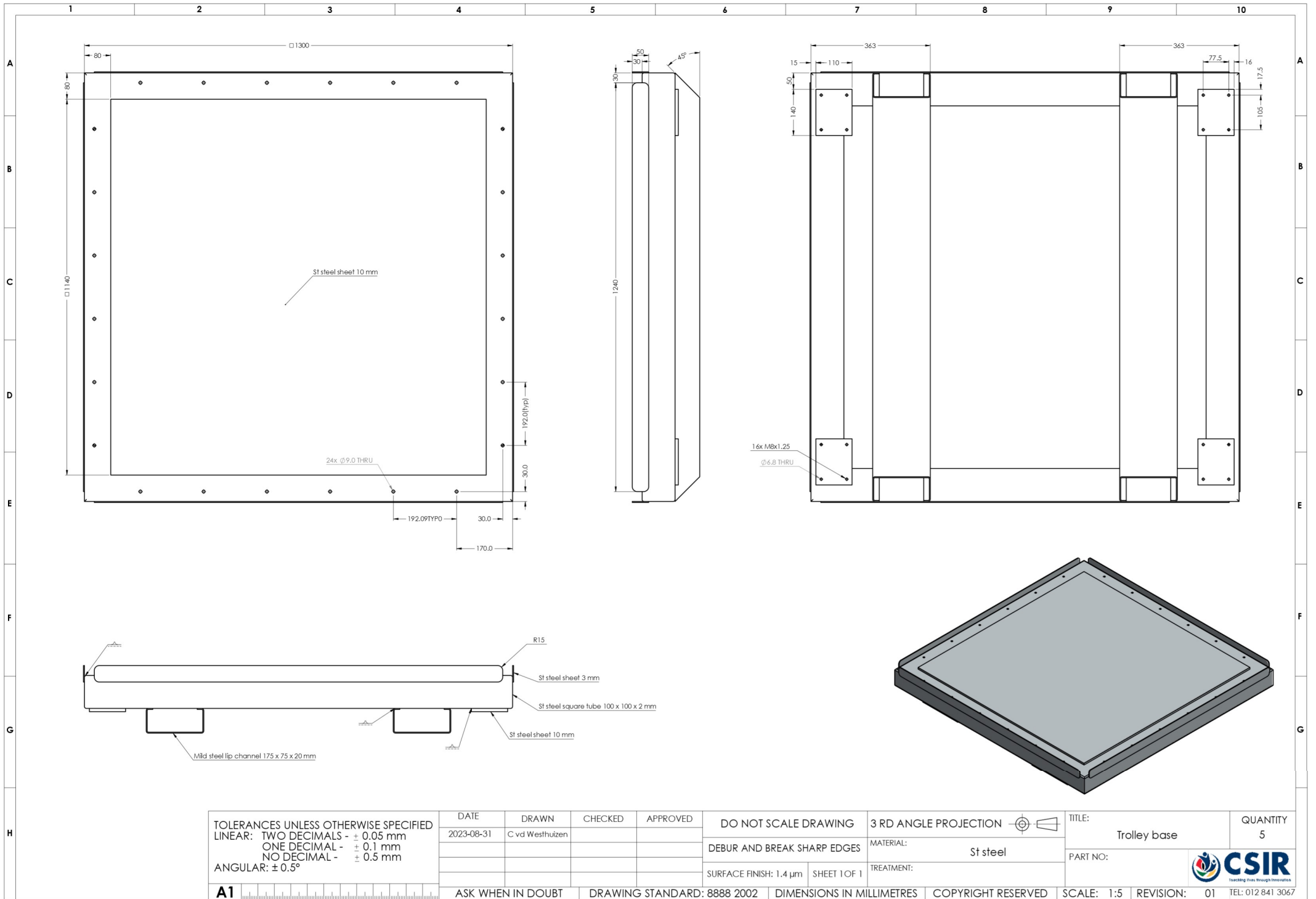

TOLERANCES UNLESS OTHERWISE SPECIFIED LINEAR: TWO DECIMALS - ± 0.05 mm ONE DECIMAL - ± 0.1 mm NO DECIMAL - ± 0.5 mm ANGULAR: ± 0.5°	DATE	DRAWN	CHECKED	APPROVED
	2023-08-31	C vd Westhuizen		

DO NOT SCALE DRAWING	3 RD ANGLE PROJECTION
DEBUR AND BREAK SHARP EDGES	MATERIAL: St steel
SURFACE FINISH: 1.4 µm	SHEET 1 OF 1

TITLE: Trolley base	QUANTITY: 5
PART NO:	

