

Annexure B1 – Technical Requirements

**The Provision of Johannesburg Metro Core and CSIR
Pretoria to Teraco Isando Dark Fibre Links for the South
African National Research Network (SANReN).**

RFP No. 3614.1/03/06/2024

Table of Contents

1	Requirement Level Keywords	7
2	Technical Compliance	7
2.1	Technical Evaluation Criteria	7
3	Link Requirements	8
4	Link specifications	8
4.1	Context	8
4.2	End Points	10
5	Fibre Requirements	12
5.1	Fibre pairs	12
5.2	Optical fibre specifications	12
5.3	Splicing specifications	12
5.4	Termination Details	13
5.5	Civil Build Specifications	13
6	Reliability	13
6.1	Service Requirements	13
6.2	Maintenance	14
7	Project Plan	15
8	Acceptance Documentation	16
8.1	Test results	16
8.2	Customer Acceptance Certificates	16
8.3	Sample Acceptance Documentation	17

Glossary

Abbreviation	Term	Description
CAC	Customer Acceptance Certificate	Certificate of Acceptance that the SANReN customer needs to sign off on when work done (including civil work) is done on the SANReN customer's premises.
CSIR	Council for Scientific and industrial Research	A statutory body established in terms of Scientific Research Council Act 46 of 1988, as amended
GIS	Geographic Information System	A system designed to capture, store, manipulate and visualise spatial or geographic data.
IETF	Internet Engineering Task Force	A body that defines standard Internet operating protocols such as TCP/IP.
IS	Internet Solutions	Internet Solutions Data Centre

Abbreviation	Term	Description
ITU	International Telecommunication Union	The International Telecommunication Union, originally the International Telegraph Union, is a specialized agency of the United Nations that is responsible for issues that concern information and communication technologies. It is the oldest global international organization. Headquarters: Geneva, Switzerland Founded: 17 May 1865
LC/APC	Lucent/Little/Local Connector - Angled Physical Contact	Fibre optic connector of the LC type with angle-polishing on fibre end-face.
LC/UPC	Lucent/Little/Local Connector - Ultra Physical Contact	Fibre optic connector of the LC type with non-angled polishing on fibre end-face.
ODF	Optical Distribution Frame	A passive device that terminates fibre cables.
PoP	Point of Presence	A location where networking equipment may be accessed.
RFP	Request for Proposal	A request for organisations and companies to submit a proposal to supply goods and services to CSIR

Abbreviation	Term	Description
RU	Rack Unit	Unit of measure describes the height of electronic equipment designed to mount in a 19-inch rack. One rack unit is 1.75 inches (44.45 mm) high. ¹
SANReN	South African National Research Network	The South African National Research Network (SANReN) is a high-speed network dedicated to science, research, education and innovation traffic.
UJ	University of Johannesburg	Institution of Higher Learning
WITS	University of the Witwatersrand	Institution of Higher Learning

1

Definition of Terms

Term	Definition
Attenuation	Gradual loss in intensity of light through the fibre-optic medium. Specified in decibel (dB) for light at a specific wave-length.
Chromatic Dispersion	The phenomenon where the phase and group velocity of light in an optical fibre is dependent on the frequency of the light.
Cross Connect	Refers to a fibre connection between separate units of facilities within a data centre. A cross connect is required between the SANReN terminating point and the bidder's terminating point if a link terminates in a datacentre, e.g. Africa Data Centres, Internet Solutions ,Teraco, etc.
Fibre Link	The contiguous fibre between two sites or Points of Presence
Fibre Pair	Consisting of two fibre cores/strands.
Polarization mode dispersion	When different polarizations of light travel at different speeds due to imperfections and asymmetries in the optical fibre, results in spreading of optical pulses.
Underground Fibre Required	Only Underground Fibre solutions will be considered.

Technical Requirements

Bidders must comply with the technical requirements in this document. These requirements will be evaluated in the Technical Compliance Matrix – Annexure C1. Bidders that wish to respond with solutions for this project must complete a **separate tab/sheet for each link proposed** in the Annexure C1 – Technical Compliance Matrix. Failure to complete the technical compliance matrix in full will result in the bidder being eliminated from evaluation.

1 Requirement Level Keywords

To eliminate ambiguity, bidders are to interpret the meaning of functional (technical) requirements using the keywords; "must", "must not", "required", "shall", "shall not", "should", "should not", "recommended", "may", and "optional", as defined by the IETF RFC (Request For Comments) document designated as RFC2119.

2 Technical Compliance

Bidders shall note the evaluation criteria applicable, and the weights attached to each criterion and complete the Technical Compliance Matrix accordingly.

2.1 Technical Evaluation Criteria

- The evaluation of the bidder's proposal will be based on their response to the Technical Compliance Matrix (in spreadsheet format) – Annexure C1.
- The bidder must complete the Technical Compliance Matrix in accordance with the instructions tabled in the Technical Compliance Matrix spreadsheet. The Technical Compliance Matrix is a mandatory submission designed to facilitate evaluation.
- Each link proposed will be evaluated individually and must be completed in a **separate tab** in Annexure C1.
- Proposals with functionality / technical points of less than the pre-determined minimum overall percentage of 70% and less than 50% on any of the individual

criteria will be eliminated from further evaluation on Price and Preference Points Evaluation.

3 Link Requirements

Bidders are invited to offer proposals for dark fibre links specified in **Table 1** of this document. The dark fibre links must be capable of transmitting multiple wavelengths of a bit rate of at least 100 Gbps between the end points specified below in **Table 1**. The bidders must ensure that their solution adheres to **all the requirements specified** in the sections that follow. Bidders must be cognisant of the following:

- The routing of the fibre will be dependent on the bidder's available infrastructure, and the bidder must ensure that it is optimised for minimum total distance.
- GIS Maps indicating the proposed routes in ESRI Shapefile or KML format must be provided, as well as diagrams annotated with sufficient detail to allow the CSIR to identify any and all shared infrastructure components, including the physical location of cable routes and ODFs (fibre optic patch panels), so that CSIR may independently determine where such infrastructure is shared among links.
- Bidders must include documentation for the physical installation and optical engineering standards used, as well as specifications of the fibre optic cable itself and the ODF to be installed at each site.
- CSIR expects the bidder to conduct a desktop study to plan for the required solution regardless whether the bidder intends to build a new route or propose an existing route;
- The bidders must cater for an access build if it is required for the solution.
- Bidders must provide an end-to-end solution, i.e. from one ODF to the next ODF.

4 Link specifications

4.1 Context

The following diagram summarises the requirements for this tender. CSIR will require the bidder to provide dark fibre between the endpoints detailed in **Table 1** below. The existing

SANReN PoP's are indicated for connection to the required infrastructure. The network diagram in **Diagram 1** below illustrates generic solutions. Bidders must adapt the sample diagram for an optimal implementation topology (optimising for a balance of cost and reliability) given available infrastructure.

Diagram 1: Schematic diagram

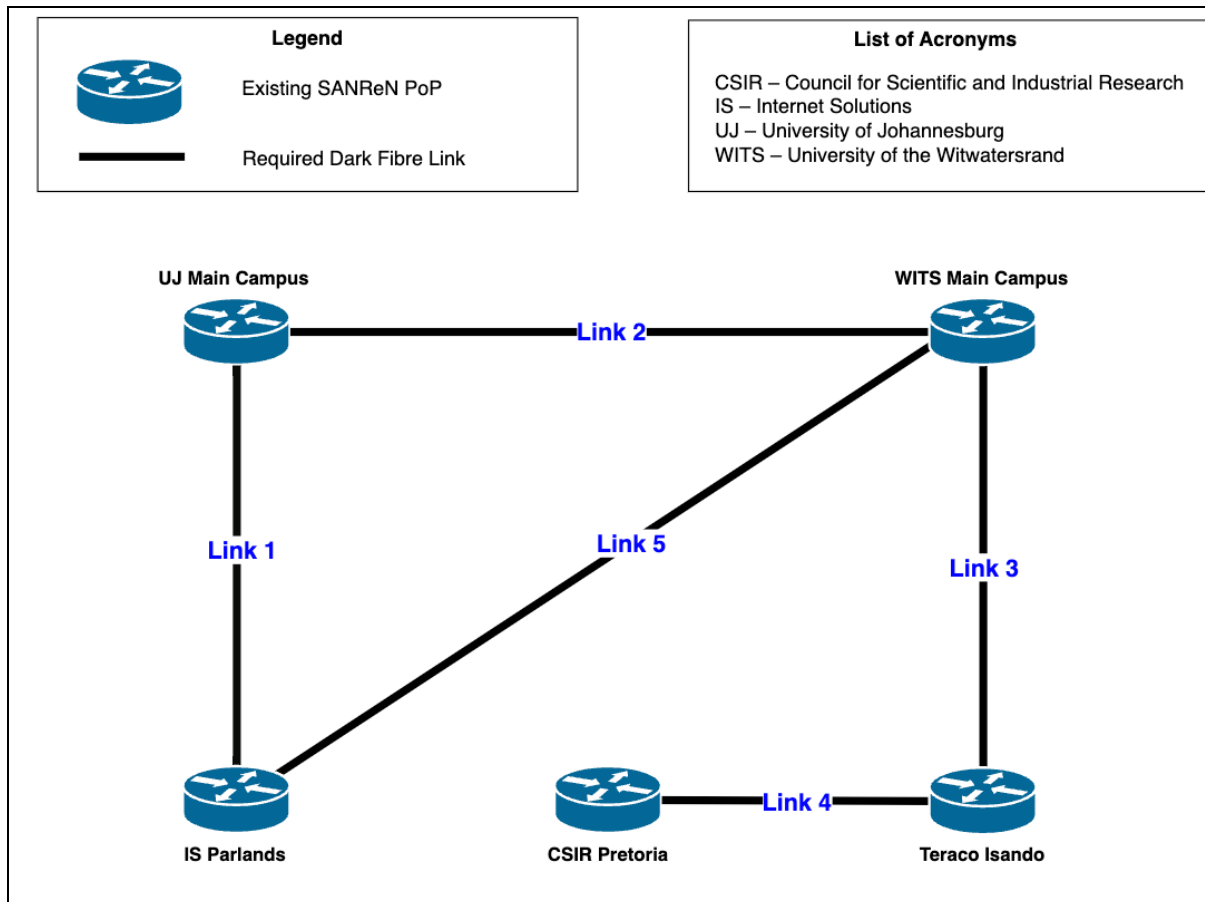

4.2 End Points

The bidder must provide dark fibre between two end points specified below in **Table 1**, where the address and GPS coordinates for each SANReN PoP are specified.

Please note that for links terminating at Teraco Isando and IS Parklands, a cross connect will be required from SANReN dedicated cabinet to the bidder's terminating point in the datacentre(s). The costs of the cross connects should be included in Annexure D1 – Pricing Schedule – Johannesburg Metro Core and CSIR Pretoria to Teraco Isando Links. Details regarding the termination point for the SANReN cabinet will be shared with the winning bidder.

4.3 Leased or otherwise shared infrastructure

Bidders that lease the underlying infrastructure offered as part of this bid with other downstream providers must disclose such information as part of their response. Bidders will not be penalised for offering solutions based leased infrastructure as long as this is disclosed.

Bidders that have provided SANReN with services that are not part of this bid must clearly indicate if their proposed solution shares any infrastructure with any such service already offered to SANReN

Table 1: Site Details

Link	Site Name	Address	Co-ordinates	Fibre Pairs
Link 1	Site A: Internet Solutions (IS) Parklands	7 – 9 Keyes Drive, Rosebank, Johannesburg, 2196	Latitude: - 26.146700 Longitude: 28.036800	2 pairs
	Site B: University of Johannesburg (UJ) Main Campus	Cnr Kingsway & University Roads, Auckland Park, Johannesburg, 2092	Latitude: - 26.183700 Longitude: 27.998800	
Link 2	Site A: University of Johannesburg (UJ) Main Campus	Cnr Kingsway & University Roads, Auckland Park, Johannesburg, 2092	Latitude: - 26.183700 Longitude: 27.998800	2 pairs
	Site B: University of the Witwatersrand (Wits) Main Campus	Solomon Mahlangu House, Jorissen Street, Braamfontein, Johannesburg, 2001	Latitude: - 26.192800 Longitude: 28.030300	
Link 3	Site A: University of the Witwatersrand (Wits) Main Campus	Solomon Mahlangu House, Jorissen Street, Braamfontein, Johannesburg, 2001	Latitude: - 26.192800 Longitude: 28.030300	2 pairs
	Site B: Teraco Isando	5 Brewery Street, Isando, Johannesburg, 0950	Latitude: - 26.138000 Longitude: 28.198020	
Link 4	Site A: Teraco Isando	5 Brewery Street, Isando, Johannesburg, 0950	Latitude: - 26.13800 Longitude: 28.198020	1 pairs
	Site B: Council for Scientific and Industrial Research (CSIR) Pretoria Campus	Building 9, Meiring Naude Road, Brummeria, Pretoria, 0001	Latitude: - 25.744750 Longitude: 28.277530	

Link	Site Name	Address	Co-ordinates	Fibre Pairs
Link 5	Site A: University of the Witwatersrand (Wits) Main Campus	Solomon Mahlangu House, Jorissen Street, Braamfontein, Johannesburg, 2001	Latitude: -26.192800 Longitude: 28.030300	2 pairs
	Site B: Internet Solutions (IS) Parklands	7 – 9 Keyes Drive, Rosebank, Johannesburg, 2196	Latitude: -26.146700 Longitude: 28.036800	

5 Fibre Requirements

5.1 Fibre pairs

The number of fibre pairs required for each link is specified in **Table 2** below, therefore bidders are requested to quote for these number of fibre pairs.

Table 2: Proposed links for procurement

Link	Source	Destination	Fibre Pairs
1	Site A: IS Parklands	Site B: UJ Main Campus	2 pairs
2	Site A: UJ Main Campus	Site B: WITS Main Campus	2 pairs
3	Site A: WITS Main Campus	Site B: Teraco Isando	2 pairs
4	Site A: Teraco Isando	Site B: CSIR Pretoria	1 pairs
5	Site A: WITS Main Campus	Site B: IS Parklands	2 pairs

5.2 Optical fibre specifications

Bidders shall provide either G.652.D or G.657.A1 or G.657.A2 fibre in compliance to the cable specifications (including chromatic and polarization mode dispersion) specified by the ITU.

5.3 Splicing specifications

Overall, the splices on the network must comply with the following:

- The two-way average splice loss at 1550 nm for all splices on a fibre span SHALL not exceed 0.08dB per splice.
- The two-way average splice loss at 1550 nm SHALL not exceed 0.10dB for any individual splice.
- Total measured losses for any single fibre span, ODF to ODF, SHALL not exceed 0.38 dB/km at 1310 nm.
- Total measured losses for any single fibre span, ODF to ODF, SHALL not exceed 0.25 dB/km at 1550 nm.
- Total measured losses for any single fibre span, ODF to ODF, SHALL not exceed 0.28 dB/km at 1625 nm.

5.4 Termination Details

- The provided fibre must terminate on an ODF in a rack that CSIR specifies.
- The connector specifications and type must be provided. The CSIR requires the use of LC/APC or LC/UPC connectors.
- All terminated fibre spans must be clearly and accurately labelled.
- Sufficient fibre slack must be provided for at all points where the fibre connects to a patch panel.

5.5 Civil Build Specifications

Bidders must provide the following information for any new builds that may be required:

- Construction Specifications, such as depth of trenching, backfill specifications, manhole specifications, marking standards and method of trenching used/proposed.
- Building entry specifications.

6 Reliability

6.1 Service Requirements

The CSIR requires that a minimum end-to-end up-time of 99% (calculated per month) to be maintained for all the links specified in **Table 1**. To manage these requirements, the CSIR encourages all bidders to include a standard SLA (Service Level Agreement)

as part of its response. The bidder must commit, as a minimum, to comply to the following criteria to pass the evaluation:

1. 24/7 access to a Network Operations Centre (NOC) to log support requests;
2. Maximum response time of 4 hours;
3. Maximum service restoration time of 8 hours; and
4. Quarterly end-to-end up-time reports for each circuit that is part of this tender.

The 99% is calculated as follows:

- Using the formula: total number of days in the month, multiplied by 24 hours multiplied by 99% equals minimum end-to-end up-time;
- For a 30-day month, 99% equates to an effective uptime of 712, 8 hours out of 720 hours, allowing for 7.2 hours of downtime in the month; and
- For a 31-day month, 99% equates to an effective uptime of 736.56 hours out of 744 hours, allowing for 7.44 hours of downtime in the month.

For bidders who wish to calculate the minimum end-to-end uptime on a quarterly basis, the number of days in the quarter under review, multiplied by 24 hours multiplied by 99% will equal the minimum end-to-end up time. Bidders need to **explicitly state** whether their minimum end-to-end uptime of 99% will be calculated either monthly or quarterly.

6.2 Maintenance

Details about the following aspects of the bidder's maintenance and support capabilities are required in order to evaluate the quality of the maintenance that the bidder will provide with respect to this link:

1. Mean Time to Repair (MTTR);
2. Same day response, Working day response only, etc.;
3. Fault Logging Procedures;
4. Maintenance down time procedures and advance warning procedures;

5. Fault Monitoring and Alerting capability;
6. Scheduled reporting of incidents & performance measurements; and
7. Customer responsibilities indicated;

The bidder must specify whether the link being provided in this tender will be actively monitored or not. If the link is actively monitored, the bidder to provide the CSIR, or the SANReN network operator, regular notifications on the status of the link and other specific details when requested.

The successful bidder will be required to provide advance notice (minimum 1 week) for any support and maintenance activities that is required on the link for the duration of the contract.

7 Project Plan

Bidders who plan to deliver the links within 6 months from the date of award will obtain full marks in the project plan section of the Technical Compliance Matrix. Bidders who plan to deliver the links after 6 months will score points as per the Technical Compliance Matrix.

Bidders must provide a schedule with timelines for the delivery of the link.

Bidders must submit a project plan and schedule for this Project. The project plan must, at a minimum, cover the following items:

1. Planning Planned activities (Required)
2. Last Mile Civil Works (if applicable)
 - a. Way Leaves
 - b. Trenching
 - c. Blowing Fibre

3. Access Build (if applicable)
 - a. Civil Works from bidder's nearest manhole to PoP's Access Build
 - b. Pulling/Blowing fibre into the PoPs
4. Link Testing (Required)
5. Handover (Required)

8 Acceptance Documentation

In accepting a link(s), the CSIR will require several documents:

1. Test results for link(s).
2. CACs for the access builds at the end points (if applicable).
3. As-deployed documentation e.g. updated KML file; and
4. Acceptance test certificate documentation.
5. Photographs of the deployed equipment/ODF at each endpoint with clearly identifiable and labelled demarcation points

8.1 Test results

The test results are to be provided for each fibre provided by the bidder. The following information must be included on the Test Result Sheet / Acceptance Test Sheet:

1. Both Summarised and Detailed OTDR Test results. This must include:
 - a. Fibre link designation
 - b. Fibre core number
 - c. Attenuation figures and return loss specifications and results.
 - d. Chromatic and Polarisation Mode Dispersion measurements.
2. Logical diagram of each link showing where splices and patches occur in the link.
3. Physical Routing GIS file/maps of the fibre that was provisioned in ESRI Shapefile or KML format.

8.2 Customer Acceptance Certificates

For access builds, CACs need to be signed off to ensure that all involved parties are satisfied with the work done by the supplier including required plans developed by the supplier be approved by relevant parties.

8.3 Sample Acceptance Documentation

Bidders must provide sample test results for previous similar work. The sample of the test result documentation must include samples of all acceptance documentation described above.