



**Request for Quotation (RFQ) for the supply of a Bottom Drain Valve for a 200L  
bioreactor to the CSIR**

**RFQ No. 5532/04/10/2019**

Date of issue:	Friday, 20 September 2019
Closing Date and Time:	Friday, 04 October 2019 at 16h30 ( <b>Late tenders will not be considered</b> )
Submission and Contact details:	For submission of quotations or any other enquiries: Email: <a href="mailto:tender@csir.co.za">tender@csir.co.za</a> ( <b>Please use RFQ No. as subject reference</b> )

## 1 INVITATION FOR QUOTATION

The CSIR has a number of stainless steel bio-reactors that require refurbishing and/or replacement parts. We are looking for a supplier to fabricate and supply these parts urgently.

Quotations are hereby invited for the supply of a Bottom Drain Valve for the 200L Bioreactor to the CSIR.

## 2 QUOTATION REQUIREMENTS

The supplier is required to quote on a new valve as per the below and according to the diagram below:

- SVP Bottom seat valve manual DN25
- Tank connection suitable for existing male flange
- Housing outlet: 30 Deg with opposite flushing port D10
- Replacement seal kit
- Product side gaskets for SVP bottom seat valve DN25
- Hand wheel 4 squares

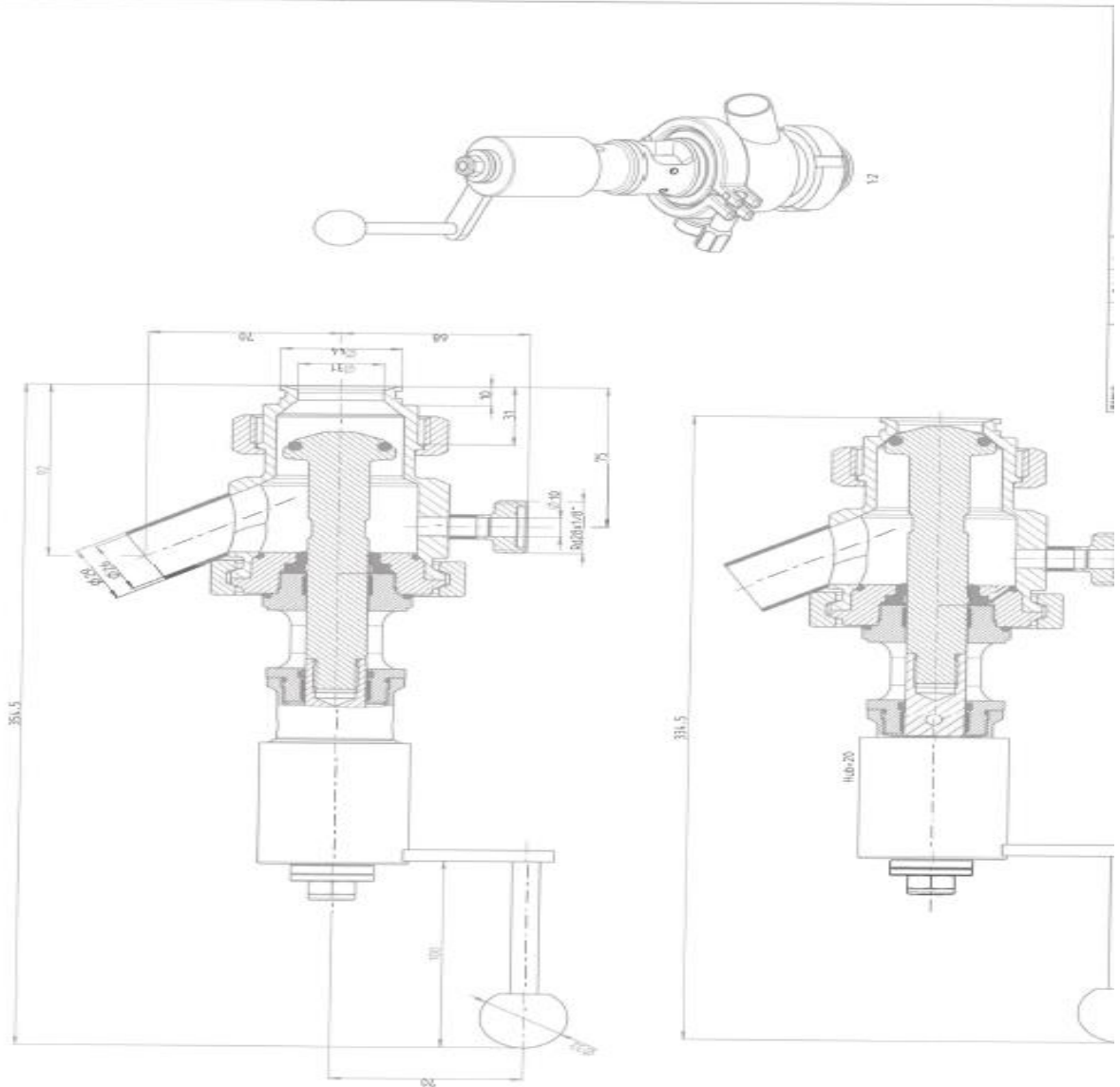

**NB: The supplier is required to submit datasheets of the items they are quoting on and they must be clearly referenced on quotation**

Additional quotation requirements (These must be submitted with and indicated in quote):

1. The bidder must submit quotation on their official company letterhead.
2. The bidder must indicate lead time on their quotation.
3. Delivery to be made to CSIR Pretoria, South Africa.

### **3 Specification Requirements**

The bidder must quote as per the above technical drawing.

#### **Mandatory documents required / returnables:**

- Current company profile clearly showing the company's core business activities. The profile must highlight the expertise of the bidder in performing similar mechanical engineering works to the scope of this RFQ.
- The bidder must provide a minimum of three (3) written testimonial letters from at least 3 different clients for similar engineering works performed in the last three (3) years. NB- (Similar= designing, manufacturing, and supplying various mechanical parts, tools, and components including mechanical seals and valves)
- The bidder must provide the completed schedule of experience (Appendix A) below
- Design specifications of the equipment. Provision of sketches or drawings of proposed mechanical seal and provide product datasheets.  
*(The supplier may be requested to provide their own engineering drawing for approval by the CSIR prior to awarding of contract or PO).*

**NB:** *Non-submission of the above-mentioned documents as well as any deviation from the above quotation requirements and specifications may deem your submission unresponsive and may thus result in your submission not being considered for Price and BBEE evaluation.*

#### **4 EVALUATION CRITERIA**

- 4.1 Selection of suppliers will be based on the 80/20 preference point system.
- 4.2 Provide a B-BBEE Certificate, or letter of exemption indicating the B-BBEE Status level. (RSA suppliers only)
- 4.3 No B-BBEE status will equal zero points.
- 4.4 Indicate CSD number (National Treasury Central Supplier Database) on quotation. If not registered yet on CSD, use [www.csd.gov.za](http://www.csd.gov.za) to register.
- 4.5 No order will be issued or no contract will be signed without a valid CSD number.
- 4.6 Elimination Criteria:  
Suppliers will be eliminated under the following conditions:
  - Late submission of Quotes;
  - If supply does not submit quotation on their official company letterhead;
  - Submission at wrong location or incorrect email address (***Please submit electronically to [tender@csir.co.za](mailto:tender@csir.co.za)***);
  - Non-submission of company profile;
  - If the supplier fails to submit any of the mandatory/returnable documents

#### **5 PRICING QUOTATION**

- 5.1 Price needs to be provided in South African Rand (excl. VAT), with details on price elements that are subject to escalation and exchange rate fluctuations clearly indicated.
- 5.2 Price should include additional cost elements such as freight, insurance until acceptance, duty where applicable, etc.
- 5.3 Payment will be according to the CSIR Payment Terms and Conditions.

**The price should be firm and inclusive of costs and all services required to deliver the required goods and/or services.**

**6 OTHER TERMS AND CONDITIONS**

6.1 The supplier shall under no circumstances offer, promise or make any gift, payment, loan, reward, inducement, benefit or other advantage, which may be construed as being made to solicit any favour, to any CSIR employee or its representatives. Such an act shall constitute a material breach of the Agreement and the CSIR shall be entitled to terminate the Agreement forthwith, without prejudice to any of its rights.

6.2 A validity period of 90 days will apply to all quotations except where indicated differently on the quote.

**7 No goods and/or services should be delivered to the CSIR without an official CSIR Purchase order. The CSIR purchase order number must be quoted on the invoice. Invoices without CSIR purchase order numbers will be returned to supplier.**

**8 Note: This is not a Purchase Order.**

**APPENDIX A – Schedule of experience & contactable references**

Firm: Contact Person, email and Telephone Number	Consulting Principal Agent / Engineer (where applicable): Contact Person and Telephone Number	Nature Of Work	Value of Work (Inclusive of Vat)	Completion Date

Signed \_\_\_\_\_ Date \_\_\_\_\_

Name \_\_\_\_\_ Position \_\_\_\_\_

Bidder \_\_\_\_\_