



Request for Quotation (RFQ) for Provision of Services for Plastic Injection Moulds for Companies Supported by the CSIR

RFQ No- 5974/30/11/2022

Date of issue:	16 November 2022
Closing Date and Time:	30 November 2022 @ 16:30
RFQ Number	5974/30/11/2022
Contact details:	<p>For submission of quotations or any other enquiries: Email: tender@csir.co.za (Please use RFQ Number as subject reference)</p> <p>Mail size is limited to 25MB, if the document exceeds this limit, please send multiple mails. Cloud submissions will not be accepted</p>
CSIR business hours	08h00 – 16h30

1. INVITATION FOR QUOTATION

Quotations are hereby invited for the manufacturing and supply of a base and a cover plastic injection moulds for water filter.

2. QUOTATION REQUIREMENTS

- Experienced service provider is required to manufacture and supply plastic injection moulds for a plastic water filter bottom and top sections.
- The moulds must be made from 2312 steel and the backing plates from mild steel. The estimated weight of the two moulds is 13500KG.

- The mould for the bottom section is 900x900 mm and the height is 1056 mm. The mould for the top section is 900x900 mm and the height is 812 mm
- Changes to the design drawings are not allowed, the manufacturer must produce according to the approved designs as requested by the client.
- Demonstrate a proven track record of at least 5 successful manufacturing of moulds for manufacturing companies in South Africa.
- Relevant and contactable references in South African manufacturing sector.

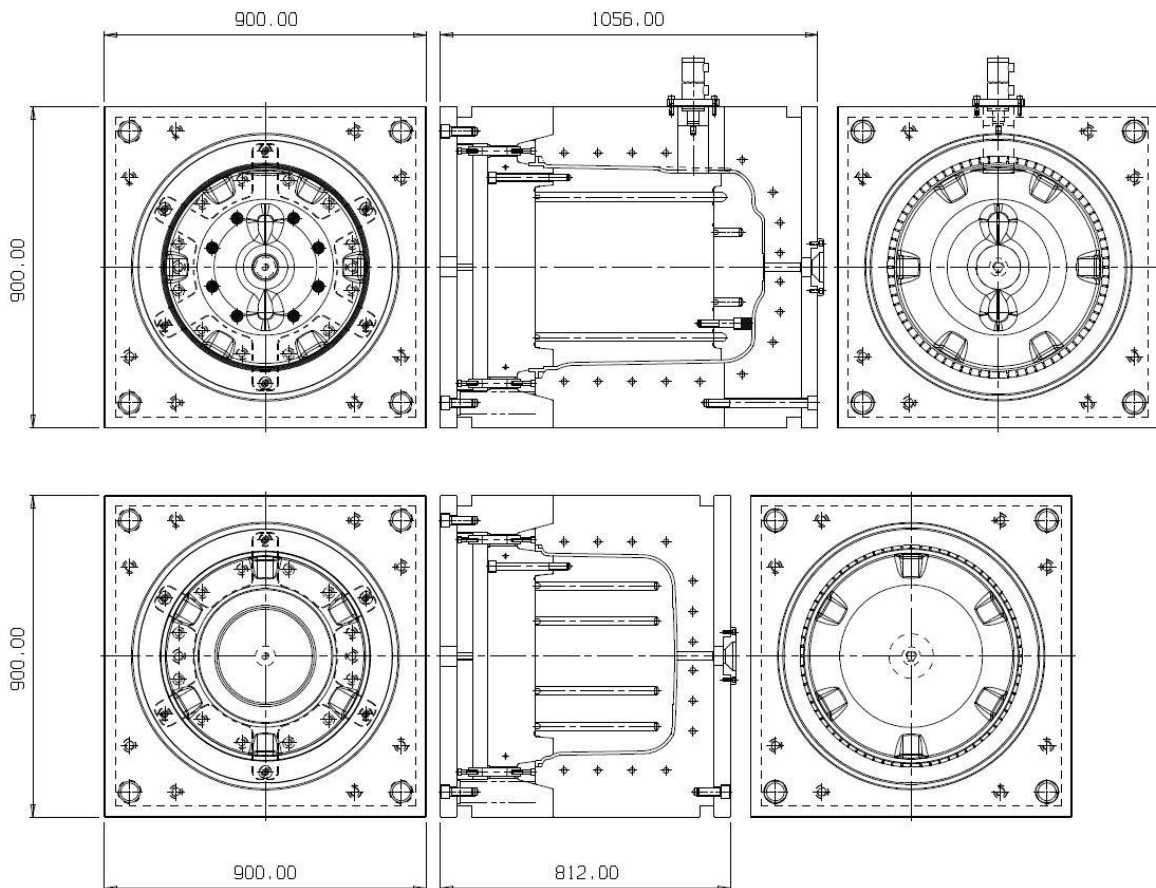

3. ELIMINATION CRITERIA

- 3.1 Failure to adhere to the bid specification requirements of the request for quotation.
- 3.2 Submission of quotation after closing date and time stated above
- 3.3 Submission at the incorrect email address – submissions must be made electronically to tender@csir.co.za
- 3.4 If the bidder is listed on the NT database of restricted suppliers.
- 3.5 If the bidder is registered on the NT Register of Tender Defaulters.
- 3.6 If the bidder did not submit a fully completed and signed **SBD 1 and SBD 4** Forms

4. EVALUATION CRITERIA

- 4.1 Selection of suppliers will be based on the **80/20** preference point system.
- 4.2 Provide a valid copy of a B BBEE Certificate or valid affidavit. No B BBEE status will equal to zero points. B BBEE certificate must be issued by SANAS accredited agency or a valid sworn affidavit in line with DTIC regulations. (RSA suppliers only).

B BBEE Verification Agency issued Certificate can be verified on SANAS website on Verification Agency (B BBEE) under Accredited Facilities (Quick Access Links): <https://www.sanas.co.za/Pages/index.aspx> to check validity of the B BBEE Certificate.

- 4.3 Indicate CSD number (National Treasury Central Supplier Database) on quotation. If not registered yet on CSD, use www.csd.gov.za to register.
- 4.4 No order will be issued, or no contract will be signed without a valid CSD number.

5. PRICING QUOTATION

- 5.1 Price needs to be provided in South African Rand (excl. VAT), with details on price elements that are subject to escalation and exchange rate fluctuations clearly indicated.
- 5.2 Price should include additional cost elements such as freight, insurance until acceptance, duty where applicable, etc.
- 5.3 Payment will be according to the CSIR Payment Terms and Conditions.

The price should be firm and inclusive of costs and all services required to deliver on the required goods and/or services.

6. OTHER TERMS AND CONDITIONS

- 6.1 The supplier shall under no circumstances offer, promise, or make any gift, payment, loan, reward, inducement, benefit, or other advantage, which may be construed as being made to solicit any favour, to any CSIR employee or its representatives.
- 6.2 Such an act shall constitute a material breach of the Agreement and the CSIR shall be entitled to terminate the Agreement forthwith, without prejudice to any of its rights.

7. CSIR RESERVES THE RIGHT TO

- 7.1 Extend the closing date.
- 7.2 Verify any information contained in a submission.
- 7.3 Request documentary proof regarding any tendering issue.
- 7.4 Give preference to locally manufactured goods.
- 7.5 Appoint one or more service providers, separately or jointly (whether or not they submitted a joint proposal).
- 7.6 Award this RFQ as a whole or in part.
- 7.7 Cancel or withdraw this RFQ as a whole or in part.

8 No goods and/or services should be delivered to the CSIR without an official CSIR Purchase order. CSIR purchase order number must be quoted on the invoice. Invoices without CSIR purchase order numbers will be returned to supplier.

9 Note: This is not a Purchase Order.

DECLARATION BY TENDERER

Only tenderers who completed the declaration below will be considered for evaluation.

RFQ No: 5974/30/11/2022

I hereby undertake to render services described in the attached tendering documents to CSIR in accordance with the requirements and task directives / quotation specifications stipulated in **RFQ No. 5974/30/11/2022** at the price/s quoted. My offer/s remains binding upon me and open for acceptance by the CSIR during the validity period indicated and calculated from the closing date of the quotation.

I confirm that I am satisfied with regards to the correctness and validity of my quotation; that the price(s) and rate(s) quoted cover all the services specified in the quotation documents; that the price(s) and rate(s) cover all my obligations and I accept that any mistakes regarding price(s) and rate(s) and calculations will be at my own risk.

I accept full responsibility for the proper execution and fulfilment of all obligations and conditions devolving on me under this quotation as the principal liable for the due fulfilment of this quotation.

I declare that I have no participation in any collusive practices with any tenderer or any other person regarding this or any other quotation.

I accept that the CSIR may take appropriate actions, deemed necessary, should there be a conflict of interest or if this declaration proves to be false.

I confirm that I am duly authorised to sign this quotation.

NAME (PRINT)

CAPACITY

SIGNATURE

NAME OF FIRM

DATE.....

WITNESSES	
1
2
DATE:	